

AIRSTREAM GRAIN CONDITIONING SYSTEMS

1 9 9 7

# DRYER OPERATION AND SERVICE MANUAL



**PNEG-339  
1100 SERIES SINGLE FAN  
PORTABLE DRYER  
MODELS**



**AIRSTREAM**  
a division of  
THE GSI GROUP





**TABLE OF CONTENTS**

Warranty.....4

Safety First.....5

Safety Alert Decals.....6

Safety Precautions.....7

Dryer Control Panel Featuring The Electronic Monitoring Control System.....8

    Safety Circuit Shutdown Messages.....13

Dryer Pre Start Checks.....14

    Pre Season Inspection.....14

Dryer Start Up.....18

    Continuous Flow And Continuous Batch Start Up Procedure.....18

    Continuous Flow Metering Roll Settings.....19

    Continuous Batch Metering Roll And Timer Settings.....22

1100 Series Dryer Service Guide.....23

    Seasonal Inspection And Service.....24

    Suggested Lubricants.....25

    Fan Propellor Removal And Installation.....26

    Fan Motor Removal And Installation.....27

    Heater Parts Removal And Installation.....28

    Metering Roll Servicing.....29

    How To Determine A Metering Roll Problem.....30

    Wiring Diagrams.....31

    Trouble Analysis Procedure.....41

    Quick Reference Guide.....46

    Notes.....47

## WARRANTY

THE GSI GROUP, INC. ("GSI") WARRANTS ALL PRODUCTS MANUFACTURED BY GSI TO BE FREE OF DEFECTS IN MATERIAL AND WORKMANSHIP UNDER NORMAL USAGE AND CONDITIONS FOR A PERIOD OF TWENTY-FOUR MONTHS AFTER RETAIL SALE TO THE ORIGINAL END USER OF SUCH PRODUCTS. GSI'S ONLY OBLIGATION IS, AND PURCHASER'S SOLE REMEDY SHALL BE FOR GSI, TO REPAIR OR REPLACE, AT GSI'S OPTION AND EXPENSE, PRODUCTS THAT, IN GSI'S SOLE JUDGMENT, CONTAIN A MATERIAL DEFECT DUE TO MATERIALS OR WORKMANSHIP. ALL DELIVERY AND SHIPMENT CHARGES TO AND FROM GSI'S FACTORY WILL BE PURCHASER'S RESPONSIBILITY. EXPENSES INCURRED BY OR ON BEHALF OF THE PURCHASER WITHOUT PRIOR WRITTEN AUTHORIZATION FROM AN AUTHORIZED EMPLOYEE OF GSI SHALL BE THE SOLE RESPONSIBILITY OF THE PURCHASER.

EXCEPT FOR THE ABOVE STATED EXPRESS LIMITED WARRANTIES, GSI MAKES NO WARRANTY OF ANY KIND, EXPRESSED OR IMPLIED, INCLUDING, WITHOUT LIMITATION, WARRANTIES OF MERCHANTABILITY OR FITNESS FOR A PARTICULAR PURPOSE OR USE IN CONNECTION WITH (i) PRODUCT MANUFACTURED OR SOLD BY GSI OR (ii) ANY ADVICE, INSTRUCTION, RECOMMENDATION OR SUGGESTION PROVIDED BY AN AGENT, REPRESENTATIVE OR EMPLOYEE OF GSI REGARDING OR RELATED TO THE CONFIGURATION, INSTALLATION, LAYOUT, SUITABILITY FOR A PARTICULAR PURPOSE, OR DESIGN OF SUCH PRODUCT OR PRODUCTS.

IN NO EVENT SHALL GSI BE LIABLE FOR ANY DIRECT, INDIRECT, INCIDENTAL OR CONSEQUENTIAL DAMAGES, INCLUDING, WITHOUT LIMITATION, LOSS OF ANTICIPATED PROFITS OR BENEFITS. PURCHASER'S SOLE AND EXCLUSIVE REMEDY SHALL BE LIMITED TO THAT STATED ABOVE, WHICH SHALL NOT EXCEED THE AMOUNT PAID FOR THE PRODUCT PURCHASED. THIS WARRANTY IS NOT TRANSFERABLE AND APPLIES ONLY TO THE ORIGINAL PURCHASER. GSI SHALL HAVE NO OBLIGATION OR RESPONSIBILITY FOR ANY REPRESENTATIVE OR WARRANTIES MADE BY OR ON BEHALF OF ANY DEALER, AGENT OR DISTRIBUTOR OF GSI.

GSI ASSUMES NO RESPONSIBILITY FOR FIELD MODIFICATIONS OR ERECTION DEFECTS WHICH CREATE STRUCTURAL OR STORAGE QUALITY PROBLEMS. MODIFICATIONS TO THE PRODUCT NOT SPECIFICALLY COVERED BY THE CONTENTS OF THIS MANUAL WILL NULLIFY ANY PRODUCT WARRANTY THAT MIGHT HAVE BEEN OTHERWISE AVAILABLE.

THE FOREGOING WARRANTY SHALL NOT COVER PRODUCTS OR PARTS WHICH HAVE BEEN DAMAGED BY NEGLIGENT USE, MISUSE, ALTERATION OR ACCIDENT. THIS WARRANTY COVERS ONLY PRODUCTS MANUFACTURED BY GSI. THIS WARRANTY IS EXCLUSIVE AND IN LIEU OF ALL OTHER WARRANTIES EXPRESS OR IMPLIED. GSI RESERVES THE RIGHT TO MAKE DESIGN OR SPECIFICATION CHANGES AT ANY TIME.

PRIOR TO INSTALLATION, PURCHASER HAS THE RESPONSIBILITY TO RESEARCH AND COMPLY WITH ALL FEDERAL, STATE AND LOCAL CODES WHICH MAY APPLY TO THE LOCATION AND INSTALLATION.

# ROOF WARNING, OPERATION & SAFETY

## ROOF DAMAGE WARNING AND DISCLAIMER

**⚠ CAUTION!**



Excessive vacuum (or pressure) may damage roof. Use positive aeration system. Make sure all roof vents are open and unobstructed. Start roof fans when supply fans are started. Do not operate when conditions exist that may cause roof vent icing.

DC-989

GSI DOES NOT WARRANT ANY ROOF DAMAGE CAUSED BY EXCESSIVE VACUUM OR INTERNAL PRESSURE FROM FANS OR OTHER AIR MOVING SYSTEMS. ADEQUATE VENTILATION AND/OR "MAKEUP AIR" DEVICES SHOULD BE PROVIDED FOR ALL POWERED AIR HANDLING SYSTEMS. GSI DOES NOT RECOMMEND THE USE OF DOWNWARD FLOW SYSTEMS (SUCTION). SEVERE ROOF DAMAGE CAN RESULT FROM ANY BLOCKAGE OF AIR PASSAGES. RUNNING FANS DURING HIGH HUMIDITY/COLD WEATHER CONDITIONS CAN CAUSE AIR EXHAUST OR INTAKE PORTS TO FREEZE.

## DRYER OPERATION

Thank you for choosing a GSI/Airstream product. It is designed to give excellent performance and service for many years.

This manual describes the operation and service for all standard 1100 Series one fan grain dryers. These models are available for liquid propane or natural gas fuel supply, with either single phase 230

volt, or three phase 220 or 440 volt electrical power.

The principal concern of the GSI Group, Inc. ("GSI") is your safety and the safety of others associated with grain handling equipment. This manual is written to help you understand safe operating procedures, and some of the problems that may be encountered by the operator or other personnel.

As owner and/or operator, it is your responsibility to know what requirements, hazards and precautions exist, and to inform all personnel associated with the equipment, or who are in the dryer area. Avoid any alterations to the equipment. Such alterations may produce a very dangerous situation, where serious injury or death may occur.

## SAFETY ALERT SYMBOL

The symbol shown is used to call your attention to instructions concerning your personal safety. Watch for this symbol; it points out important safety precautions. It means "ATTENTION", "WARNING", "CAUTION", and "DANGER". Read the message and be cautious to the possibility of personal injury or death.



### **WARNING! BE ALERT!**

Personnel operating or working around electric fans should read this manual. This manual must be delivered with the equipment to its owner. Failure to read this manual and its safety instructions is a misuse of the equipment.

## SAFETY ALERT DECALS

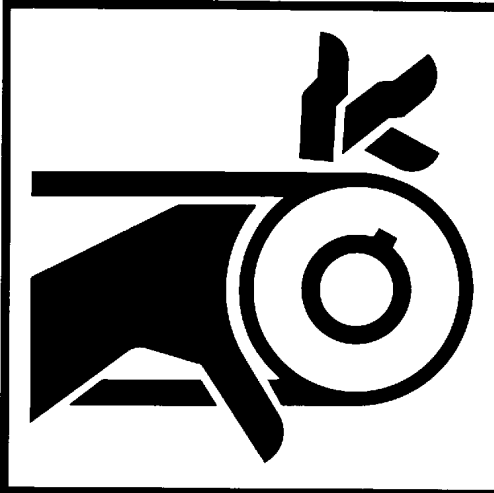

### **! DANGER**

Automatically controlled belt drive can start at any time. Keep hands clear. Failure to do so could result in serious injury or death.

DC-386

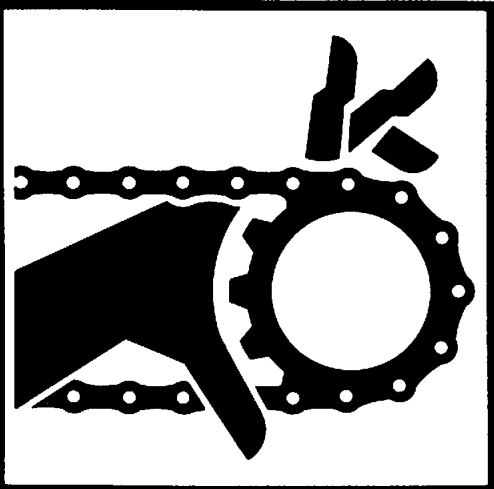

### **! DANGER**

Do not operate without shields in place. Before removing any shield, disconnect main power supply and allow all moving parts to stop. Replace shields securely before restarting unit. Failure to do so could result in serious injury or death.

DC-385



### **! DANGER**

Automatic equipment can start at any time. Do not enter until fuel is shut off and electrical power is locked in off position. Failure to do so will result in serious injury or death.

DC-384

Three decals displayed on all Airstream Dryers. Belt drives, chain driven meter rolls and combustible fuels must be treated with caution.

# SAFETY PRECAUTIONS

1. Read and understand the operating manual before trying to operate the dryer.
2. Never operate the dryer while the **guards** are removed.
3. Power supply should be OFF for service of **electrical components**. Use CAUTION in checking voltage or other procedures requiring power to be ON.
4. Check for gas leaks at all **gas pipe** connections. If any leaks are detected, do not operate dryer. Shut down and repair before further operation.
5. Never attempt to operate the dryer by jumping or otherwise bypassing any safety devices on the unit.
6. Set **pressure regulator** to avoid excessive gas pressure applied to burner during ignition and when burner is in operation. See chart for operating procedures. Do not exceed maximum recommended drying temperature.
7. Keep the dryer clean. Do not allow fine material to accumulate in the **plenum chamber**.
8. Keep **auger drive belts** tight enough to prevent slippage.
9. Use CAUTION in working around high speed **fans, gas burners, augers and auxiliary conveyors** which START AUTOMATICALLY.
10. Do not operate in any area where combustible material will be drawn into the **fan**.
11. Before attempting to remove and reinstall any **propellor**, make certain to read the recommended procedure listed within the servicing section of the manual.
12. Be certain that capacities of **auxiliary conveyors** are matched to dryer **auger** capacities.
13. Clean grain is easier to dry. Fine material increases resistance to airflow and requires removal of extra moisture.

**READ THESE INSTRUCTIONS  
BEFORE OPERATION AND SERVICE**

**SAVE FOR FUTURE REFERENCE**

## **USE CAUTION IN THE OPERATION OF THIS EQUIPMENT**

The design and manufacture of this dryer is directed toward operator safety. However, the very nature of a grain dryer having a **gas burner**, high voltage **electrical equipment** and high speed **rotating parts**, does present a hazard to personnel, which can not be completely safeguarded against, without interfering with efficient operation and reasonable access to components.

Use extreme caution in working around high speed **fans**, gas-fired **heaters, augers and auxiliary conveyors**, which may start without warning when the dryer is operating on automatic control.

---

**KEEP THE DRYER CLEAN  
DO NOT ALLOW FINE  
MATERIAL TO ACCUMULATE  
IN THE PLENUM CHAMBER  
OR SURROUNDING THE  
OUTSIDE OF THE DRYER**

---

Continued safe, dependable operation of automatic equipment depends, to a great degree, upon the owner. For a safe and dependable drying system, follow the recommendations within this manual, and make it a practice to regularly inspect the operation of the unit for any developing problems or unsafe conditions.

Take special note of the safety precautions listed above before attempting to operate the dryer.

# DRYER CONTROL PANEL

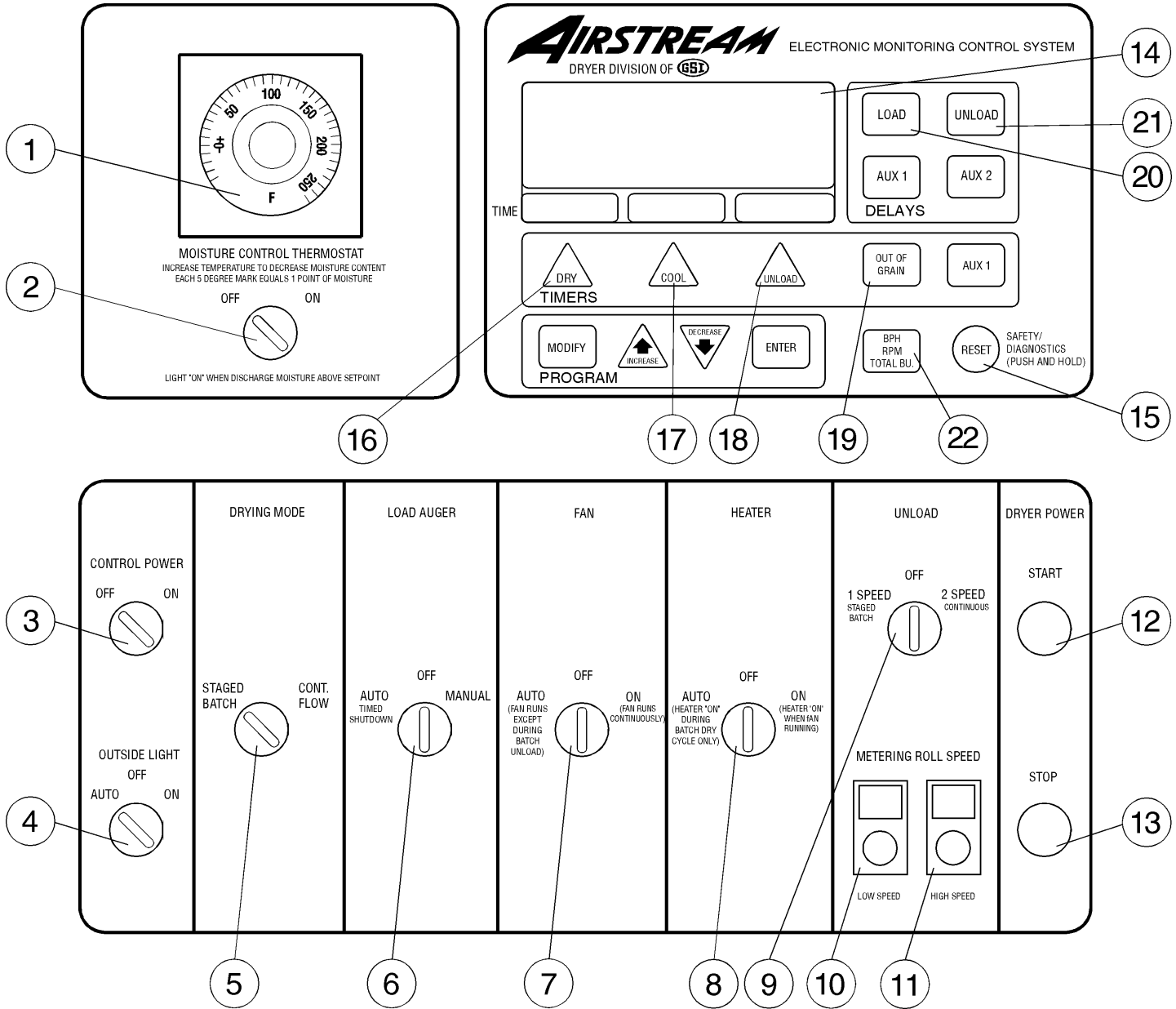

Figure 1: The grain dryer control panel with the Electronic Monitoring Control System in the upper right panel.

## DRYER CONTROL PANEL FEATURING THE ELECTRONIC MONITORING CONTROL SYSTEM

The **control panel** provides easy access to gauges and controls, and the **ILLUMINATED SWITCHES** are a quick reference for every operating function. The patent pending **Electronic Monitoring Control System** is computerized and gives instant

information about dryer operation.

**MOISTURE CONTROL THERMOSTAT (1)**

This electronic **thermostat** controls the moisture level of discharged grain by sensing grain column temperature.

**MOISTURE CONTROL SWITCH (2)**

This switch turns the power **ON** or **OFF** to the moisture control **thermostat**. It lights up when the grain column temperature is below the thermostat set point.



# DRYER CONTROL PANEL

## CONTROL POWER SWITCH (3)

The power to the **Electronic Monitoring Control System** is turned ON or OFF with this switch.

## OUTSIDE LIGHT (4)

The dryer **service light** is turned ON or OFF here. It also may be set on AUTO, which turns the light on while the dryer is running, and off if a shutdown occurs.

## DRYING MODE SWITCH (5)

This is used to select STAGED BATCH or CONTINUOUS FLOW drying. The switch will light only after the **Electronic Monitoring Control System** has been turned ON, the safety circuit is okay and the RESET button has been pressed.

## LOAD AUGER SWITCH (6)

This is used to select the operation of the **load auger**. In both the AUTO and MANUAL position the **load auger** will operate if the dryer is low on grain, and will automatically shut off when the dryer is full. In the AUTO position only, the dryer will shut down after a predetermined period of time set on the OUT OF GRAIN TIMER, or if grain flow is interrupted to the dryer. The switch will light whenever the **load auger** is operating.

Note: When this switch is set to AUTO or MANUAL it also controls the operation of any **auxiliary load equipment** being utilized, such as an auxiliary auger or conveyor.

## FAN SWITCH (7)

The **fan** is turned ON or OFF with this switch. The ON position operates the **fan** continuously during STAGED BATCH and CONTINUOUS FLOW modes. The AUTO position operates the **fan** in STAGED BATCH during the dry and cool cycle. The switch will light up whenever the airflow switch is sensing airflow and the dryer is full of grain.

## HEATER SWITCH (8)

This switch is used to turn the **burner** ON or OFF. The AUTO position operates the **burner** in STAGED BATCH during the dry cycle. The ON position will operate the **burner** only when the **fan** is running. The switch will light up when the flame sensor detects the flame.

## UNLOAD SWITCH (9)

The UNLOAD switch turns the **metering rolls** and **discharge auger** ON or OFF, and selects the operation of the metering rolls.

- In the 2 SPEED position if the MOISTURE CONTROL switch is ON, and the DRYING MODE switch is turned to CONTINUOUS FLOW, the METERING ROLL SPEED will alternate between the HIGH speed metering roll potentiometer setting and the LOW speed metering roll potentiometer setting depending on the control signal from the MOISTURE CONTROL THERMOSTAT. The **discharge auger** will operate continuously.

- In the 1 SPEED position, if the MOISTURE CONTROL switch is ON, and the DRYING MODE switch is turned to CONTINUOUS FLOW, the METERING ROLL SPEED will operate at the HIGH speed metering roll potentiometer setting or turn OFF depending on the control signal from the MOISTURE CONTROL THERMOSTAT. The **discharge auger** will operate whenever the **metering rolls** are operating.

- In both the 1 SPEED or the 2 SPEED position, if the MOISTURE CONTROL THERMOSTAT is OFF, and the DRYING MODE switch is turned to CONTINUOUS FLOW, the METERING ROLL SPEED can be manually controlled by adjusting the HIGH speed metering roll potentiometer. The **discharge auger** will operate continuously.

- If the DRYING MODE switch is turned to STAGED BATCH, the UNLOAD switch should be set to the 1 SPEED position. The **discharge auger** and **metering rolls** will only operate during the unload cycle of the staged batch operation, and the METERING ROLL SPEED is adjusted using the HIGH speed metering roll potentiometer.

Note: When this switch is set to AUTO or MANUAL it also controls the operation of any **auxiliary load equipment** being utilized, such as an auxiliary auger or conveyor.

# DRYER CONTROL PANEL

## LOW SPEED METERING ROLL POTENTIOMETER (10)

This is used to adjust the LOW speed of the **metering roll** when the 2 SPEED and MOISTURE CONTROL THERMOSTAT are in use.

## HIGH SPEED METERING ROLL POTENTIOMETER (11)

This is used to:

- Set the HIGH speed of the **metering roll** when the 2 SPEED automatic moisture control feature of the dryer is utilized.
- Set the speed of the **metering rolls** when the 1 SPEED auto-

matic moisture control feature of the dryer is utilized.

- Set the speed of the **metering rolls** during continuous flow operation when the moisture control is not used.
- Set the rate of grain discharge from the dryer during the unload cycle of staged batch dryer operation.

## DRYER POWER START SWITCH (12)

This switch starts and operates the dryer based on switch settings. If other switch settings are in the OFF position, individual dryer compo-

nents can be operated by turning the DRYING MODE switch to CONTINUOUS FLOW, pressing the DRYER POWER START button and then turning ON the desired dryer component.

## DRYER POWER STOP SWITCH (13)

This switch stops all dryer functions. If an automatic dryer shutdown occurs, first determine and correct the cause of the shutdown. Then, press the DRYER POWER STOP button to reset the dryer before restarting.

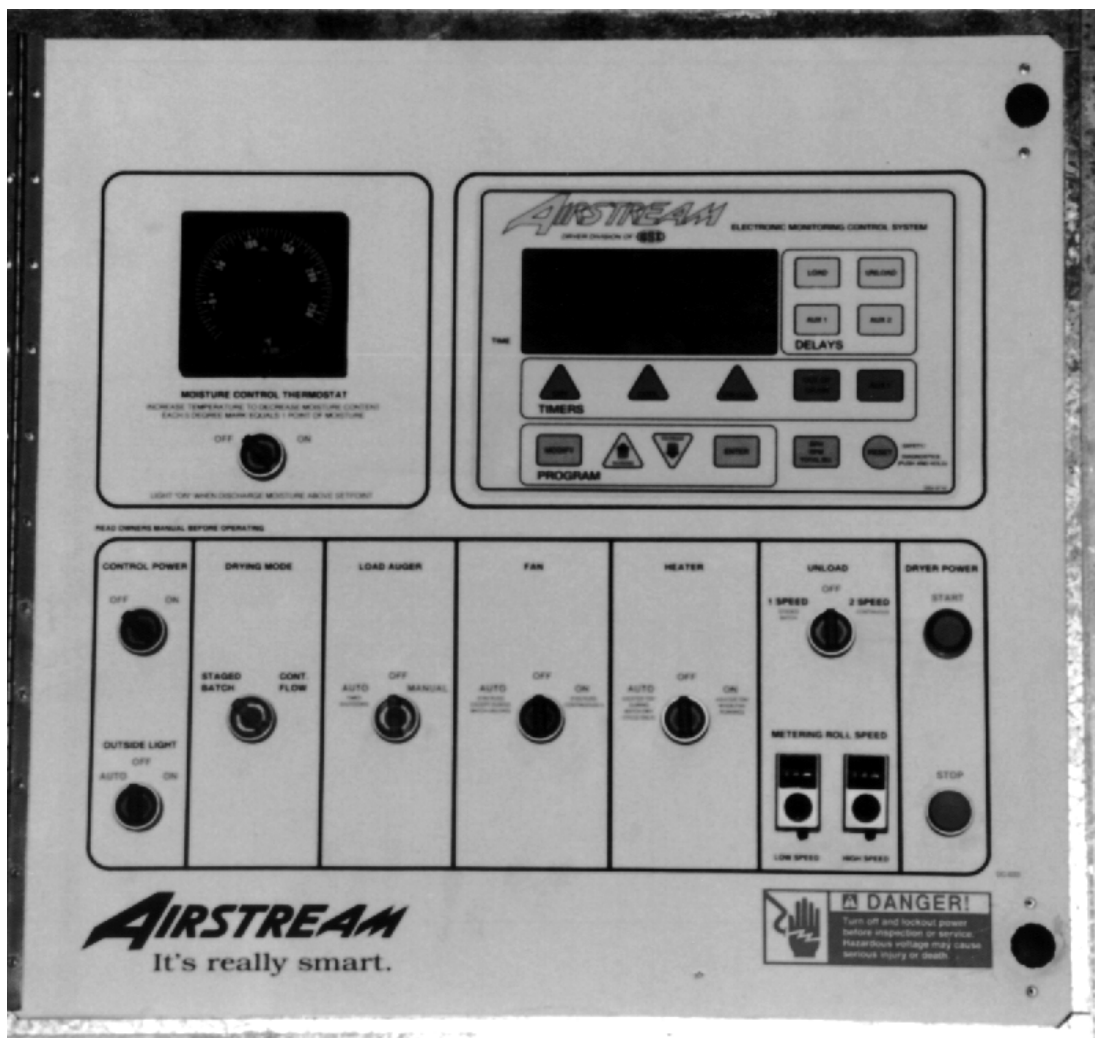

The Airstream Dryer Control Panel.

# DRYER CONTROL PANEL

## ELECTRONIC MONITORING CONTROL SYSTEM (14)

The **Electronic Monitoring Control System** (Figure 2) controls all timing functions and safety circuit checks. It is designed to simplify dryer operation by providing printed messages and warnings on its liquid crystal display (LCD).

## TURNING ON THE ELECTRONIC MONITORING CONTROL SYSTEM USING THE RESET BUTTON (15)

Turn the CONTROL POWER switch to ON. The monitor will display a copyright message and model number, total running time in hours and minutes and the current time and date. To activate the controller press the RESET button.

## SETTING THE DRY (16), COOL (17) AND UNLOAD (18) BATCH TIMERS

These switches are used to set the cycle times in the STAGED BATCH DRYING MODE only. The DRYING MODE switch must be in the STAGED BATCH position. The current settings on these three TIMERS are displayed directly above each TIMER button. To change the setting of these TIMERS follow these instructions:

1. Press the DRY, COOL or UNLOAD TIMER button.
2. Press the MODIFY button.
3. Press the INCREASE or DECREASE button to adjust the settings.
4. Press the ENTER button.

During operation the remaining time on each TIMER is displayed on the screen. If the power goes out or

if the dryer is stopped, these times are saved by the controller. When the dryer is restarted the TIMERS will continue timing down. The TIMERS will return to their initial settings by pressing the RESET button.

## SETTING THE OUT OF GRAIN TIMER (19)

If the dryer runs out of grain while the LOAD AUGER switch is in the AUTO position, the OUT OF GRAIN TIMER automatically shuts OFF the dryer after the period of time preset on the TIMER. When pressed, the display will show the amount of time left on the TIMER and the percentage of time the last load expended. A second screen will appear showing the TIMER'S setting and will allow the operator to modify it as described for setting the BATCH TIMERS.

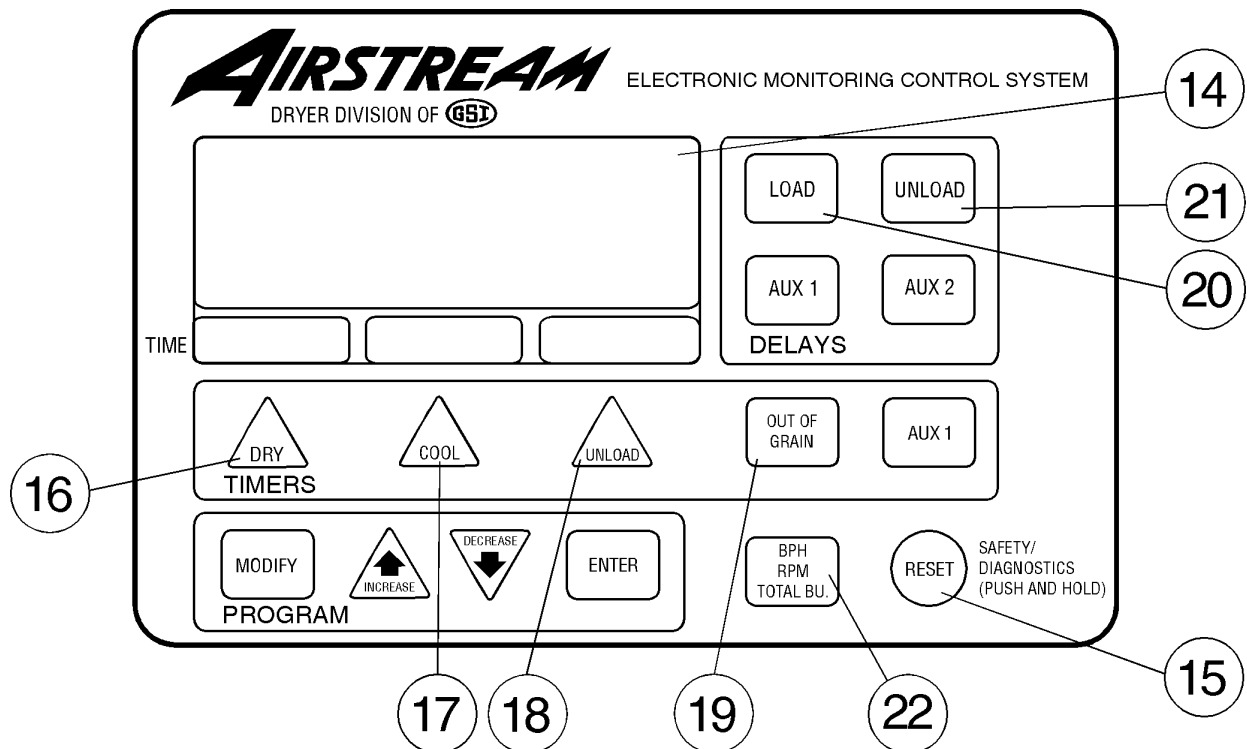
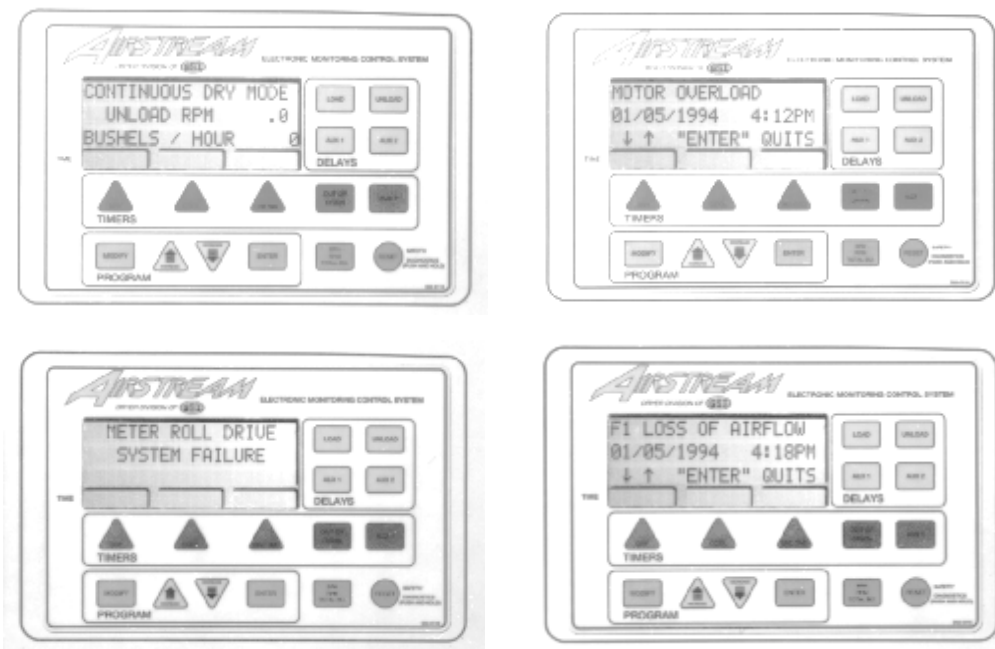

Figure 2: The Airstream Electronic Monitoring Control System

## DRYER CONTROL PANEL



The Airstream Electronic Monitoring Control System showing different LCD displays.

### SETTING THE LOAD (20) AND UNLOAD (21) DELAYS

The LOAD DELAY is used to delay the starting of the **load auger** when the dryer is unloading to prevent the **load auger** from starting and stopping. The UNLOAD DELAY is used to control the amount of time the **unload auger** runs after the **metering rolls** stop to allow for **auger** cleanout. Both the LOAD and UNLOAD DELAYS are set using the same procedure as the TIMERS. The AUX1 and AUX 2 DELAYS are presently not being used.

### UTILIZING THE BUSHEL COUNTER (22)

When operating the dryer the LCD display will show the DRYER MODE OF OPERATION on the first line, the BUSHELS PER HOUR or the METERING ROLL RPM on the second line and the TOTAL BUSHELS dried

on the third line. By pressing the BPH/RPM/TOTAL BU button the second line will alternate between the METERING ROLL RPM's or the BUSHEL PER HOUR rate. The TOTAL BUSHELS DRIED reading is the total since the bushel counter was last reset. To reset the BUSHEL COUNTER, press and hold the RESET button for five seconds. Press the ENTER button through the date and time settings and then follow the instructions displayed on the LCD for resetting the counter.

In the STAGED BATCH DRYING MODE the first line of the LCD display tells which TIMER is being used, and the second line switches between TOTAL BATCHES, UNLOAD RPM or TOTAL BUSHELS. The third line indicates TOTAL DRY TIME and the fourth line is TIME REMAINING on the TIMERS.

### DRYER SAFETY CIRCUIT

The **Electronic Monitoring Control System** continuously checks all safety circuits on the dryer, and will automatically shut the dryer down should a problem occur. The cause of the dryer shutdown will be displayed on the LCD display, and a beeper will sound on the controller. To restart the dryer after a safety shutdown, first correct the reason for the shutdown, and then press the DRYER POWER STOP button to reset the circuit. Press the START button.

The **Electronic Monitoring Control System** stores in its memory the time, date and cause for the last 25 dryer safety shutdowns. To review this information hold the RESET button in for five seconds. The procedure for reviewing the safety circuit shutdown log will be displayed on the LCD display.

# DRYER CONTROL PANEL

## SAFETY CIRCUIT SHUTDOWN MESSAGES

### BURNER VAPOR HIGH TEMPERATURE

The LP gas vapor **temperature sensor** located in the **gas pipe train** downstream from the vaporizer, has opened indicating that the vaporizer is running too hot and must be re-adjusted. This sensor is set at 200°F and automatically resets itself when cool.

### BURNER WARNING FLAME NOT DETECTED

The **flame sensor** has failed to detect a burner flame indicating that the burner has failed to light, there is a problem with the flame sensing circuitry or the dryer is not getting burner fuel.

### FAN HOUSING HIGH TEMPERATURE

The **temperature high limit** located on the **fan/burner housing** has opened, indicating an over temperature condition has occurred towards the rear of the **fan/heater housing**. This control is set at 200°F and must be manually reset.

### GRAIN DISCHARGE WARNING

The **lid on the grain discharge box** has opened, indicating that grain is not being taken away fast enough at the **discharge box**.

### LI VOLTAGE LOST

The **left circuit breaker** located on the **input/output board** of the **Electronic Monitoring Control System** has tripped, or one of the hardware timers has shut down the dryer.

### LOWER ADJUSTABLE GRAIN HIGH TEMPERATURE

An over temperature condition has occurred in the **right side** (left and right as viewed from behind the dryer) **grain column** causing the control to shut down the dryer. This control is set at 210°F and automatically resets itself when cool.

### LOWER FIXED GRAIN HIGH TEMPERATURE

An over temperature condition has occurred in the **left side** (left and right as viewed from behind the dryer) **grain column** causing the control to shutdown the dryer. This control is set at 210°F and automatically resets itself when cool.

### MOTOR OVERLOAD

One of the **thermal overloads** on either the **fan, load, unload** or **auxiliary motors** has opened, indicating an overcurrent condition. The **overloads** must be manually reset.

### OUT OF GRAIN WARNING/UNLOAD CLEANOUT

The dryer has run low on grain, and the **OUT OF GRAIN TIMER** has timed out, shutting the dryer down. The **unload auger** will clean out the dryer if in continuous flow operation.

### PLENUM HIGH TEMPERATURE

An over temperature condition has occurred inside the **dryer plenum**. This control is a 300°F limit and automatically resets itself when cool.

### METERING ROLL DRIVE SYSTEM FAILURE

The **metering roll drive system** has failed to turn. A broken chain or jammed metering roll is a possibility.

### RIGHT METERING ROLL FAILURE

The **right** (as viewed from behind the dryer) **metering roll** has stopped turning, or the sensor has been damaged.

### LEFT METERING ROLL FAILURE

The **left** (as viewed from behind the dryer) **metering roll** has stopped turning, or the sensor has been damaged.

### 12 VOLT POWER SUPPLY WARNING

The **right circuit breaker** on the **input/output board** has tripped.

### AUXILIARY SAFETY SHUTDOWN

A shutdown has occurred due to an auxiliary installed safety feature.

### BURNER SHUTDOWN LOSS OF AIRFLOW

The contacts in the **air switch** have opened due to insufficient airflow for the **burner** to operate.

### FAN FAILURE NO AIRFLOW

The contacts in the **air switch** have opened due to the **fan** not turning, or the **air switch** may need adjustment.

### FAN CANNOT START CHECK AIR SWITCH

The **air switch** contacts have closed prior to the **fan** starting, indicating a freewheeling **blade** or improper setting of the **air switch**.

# DRYER PRE START CHECKS

## PRE SEASON INSPECTION

Before the dryer is filled, thoroughly inspect the unit and check the operation of the dryer as follows.

### INSPECT THE METERING ROLLS

Open all **metering roll access doors** and inspect each compartment for any bolts, nuts or other foreign material, that may cause possible jamming of the **metering rolls**.

---

BEFORE ATTEMPTING TO OPERATE THE DRYER MAKE SURE ALL SAFETY SHIELDS ARE IN PLACE, ALL BOTTOM CLEANOUT AND REAR ACCESS DOORS ARE CLOSED AND ALL PERSONNEL ARE CLEAR OF THE DRYER

---

### SET CONTROL SWITCHES

Moisture Control Switch-ON  
Moisture Control Thermostat-MAXIMUM TEMPERATURE  
Load Switch-OFF  
Unload Switch-OFF  
Fan Switch-OFF  
Burner Switch-OFF  
Out of Grain Timer-8 MINUTE  
Load Delay-30 SECONDS  
Unload Delay-30 SECONDS  
Metering Roll Speed-LOW AND HIGH SPEED SETTINGS PUT ON ZERO  
Dry Timer-60 MINUTE  
Cool timer-20 MINUTE  
Unload timer-10 SECONDS  
Mode Switch-CONTINUOUS FLOW

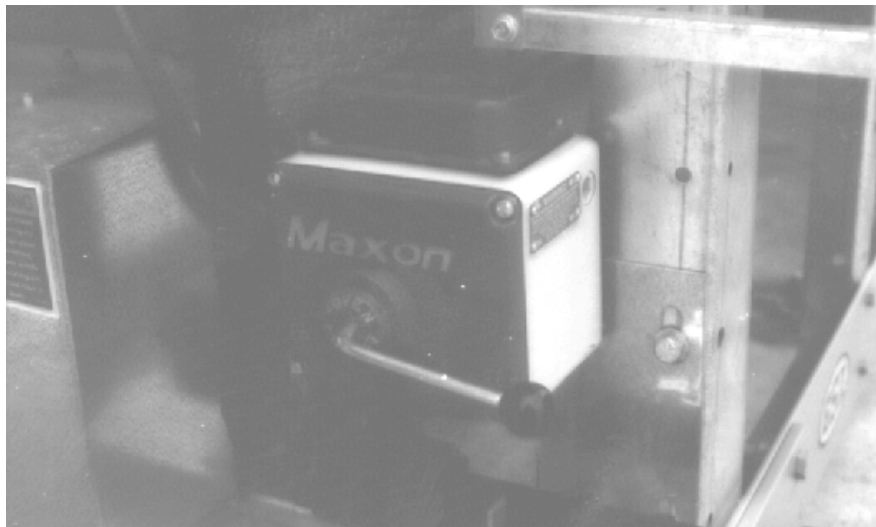

The Maxon safety shut off valve.

### ELECTRICAL POWER

Turn ON the **electrical power supply** to the dryer, set all **circuit breakers** to ON, including the **safety disconnect handle** mounted on front of the **dryer's power panel**.

### CONTROL POWER SWITCH

Turn the CONTROL POWER switch to ON. The switch will light up. A copyright message, model number, total running time in hours and minutes, current date and time will appear. At this point the controller will lock out all other dryer functions. Once the date and time appear, press RESET and the dryer will perform its safety circuit check. If a fault is found, the cause will be displayed on the LCD. If all are found safe, the controller will supply power to the **electronic fuel shut-off valve** (if so equipped) and the DRYING MODE switch will light up, indicating that the dryer is ready to be started.

### POWER START BUTTON

Push the DRYER START button, and all the selector switches on the control panel will be activated.

### FUEL CHECK

If using LP gas, make sure the tank has plenty of fuel and that the tank does not have a regulator mounted to it. If using natural gas, make sure an adequate supply is available.

If using LP gas, slowly OPEN the main **fuel supply valve** at the tank. If using natural gas turn ON the **valve** along the supply line. Then, OPEN the electronic **shut off valve** (Maxon valve), if so equipped, or OPEN the manual **shut off valve** on the dryer to allow fuel flow to the dryer. Inspect all **gas lines and connections** for possible leaks.

***Any gas leaks need to be fixed immediately!***

## DRYER PRE START CHECKS

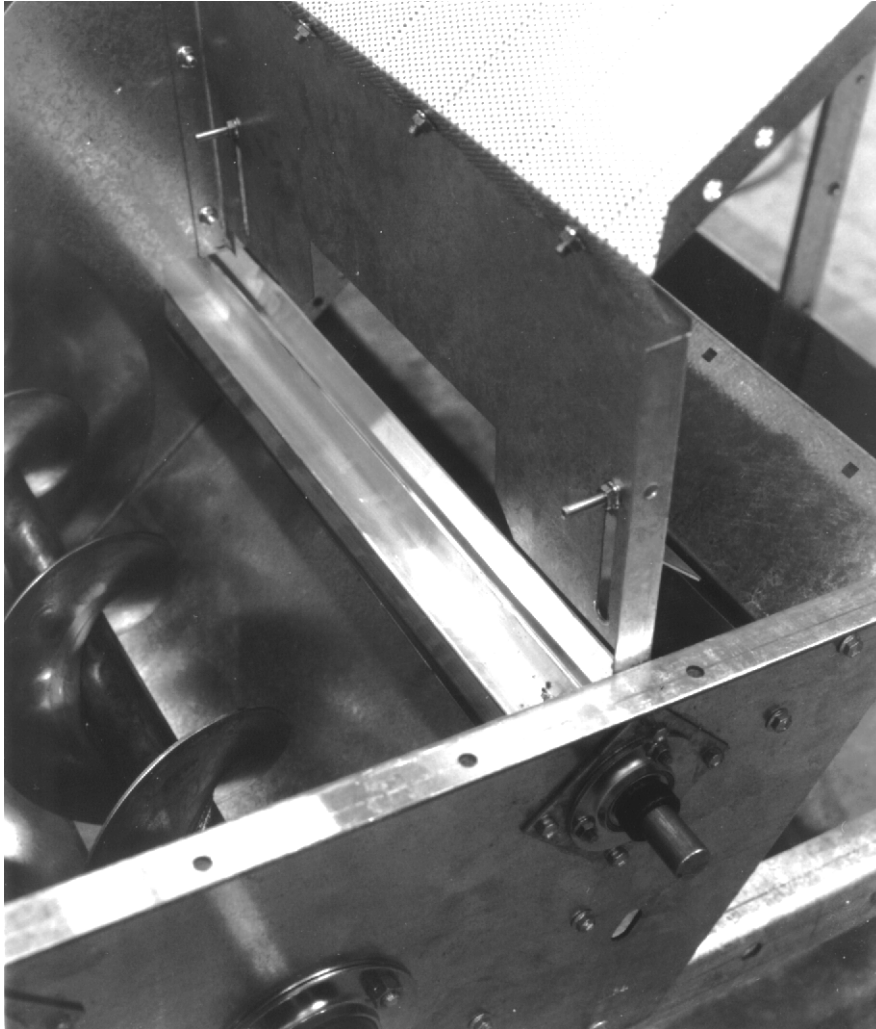

The metering roll access area.

### LOAD AUGER

With the grain supply SHUT OFF, quickly bump the LOAD AUGER switch to MANUAL, and see if the **load auger** rotates clockwise as viewed from the drive end, or counterclockwise if the dryer is a front load model. If the wet grain supply auxiliary is wired to the dryer it should also rotate in the correct direction at this time. Turn the LOAD AUGER switch to the AUTO position. The **top auger** and **wet grain supply auxiliary** should run for one minute, and then the dryer will shut down leaving the safety shutdown

message (out of grain warning) displayed. Press the DRYER POWER STOP button to reset the panel, then press the START button.

### ONE SPEED OPERATION

To check 1 speed operation place the UNLOAD switch in the 1 SPEED setting. Turn up the HIGH SPEED METERING ROLL DIAL until the **metering rolls** start rotating. The **bottom auger** should rotate counterclockwise as viewed from the drive end. The **metering roll drive motor** should rotate clockwise as viewed from the drive end of the

**gear box**. If the **dry grain take away auxiliary** is wired to the dryer, it should start and rotate in the proper direction.

### MOISTURE CONTROL THERMOSTAT

To check the MOISTURE CONTROL THERMOSTAT leave the UNLOADING switch on 1 SPEED, and slowly turn down the MOISTURE CONTROL THERMOSTAT. As the setting is decreased, the indicator light should come on and the **metering rolls** should stop operating. The **bottom auger** will stop after the 30 second clean out delay, providing that the dryer is still being held by the MOISTURE CONTROL THERMOSTAT. Rotate the MOISTURE CONTROL THERMOSTAT up to its maximum setting. The light should go off, and the **metering rolls** should restart along with the **bottom auger** if it has stopped.

To check 2 SPEED operation move the switch to the 2 SPEED position, set LOW speed on 200 and HIGH speed on 600. Slowly turn the thermostat until the MOISTURE CONTROL switch light comes ON. The METERING ROLL SPEED is now controlled by the LOW speed dial. Turning the THERMOSTAT the other way until the light goes out now leaves the **metering rolls** controlled by the HIGH SPEED DIAL.

### METERING ROLL OPERATION

To check the **metering roll** operation turn either the LOW speed or HIGH speed knob clockwise, and the ME-

## DRYER PRE START CHECKS

TERING ROLL SPEED should increase. Turning either knob counterclockwise will decrease the speed. Make sure the **drive chain** tension is properly adjusted and all sections of the **metering rolls** rotate. Turn the UNLOAD switch OFF after these checks are complete. The **bottom auger** will continue to run for 30 seconds after the switch is turned OFF to allow for cleanout.

### FAN SWITCH

Bump the FAN switch and observe the **fan** rotation. The **fan** should run counterclockwise. Sometimes on three phase models all **motors** will run backwards. They can easily be reversed by interchanging the two of three **power supply wires**. Reverse the two outside wires, L1 and L3, and leave the middle one in the same position.

Note: If the dryer is empty, the **burner** will not operate. The **fans** cannot create enough static pressure to engage the **air switch**. You will receive a loss of airflow message.

### BURNER SAFETY

To check the **burner** safety function, first make sure the main GAS VALVE is OFF. Turn the FAN switch ON and allow the **fan** to start. Then, turn the HEATER switch ON. The dryer will shut down after 20 seconds. The safety message, "Burner 1 warning flame not detected" will appear.

### BURNER TEST FIRE

START the **fan**, and then turn the HEATER switch to ON. Turn ON the fuel supply, and the **burner** should

ignite after a short purge delay of approximately 10 seconds. Gas pressure should be shown on the gauge. At this time adjust the BURNER HIGH-LOW FIRE THERMOSTAT to 200°F, causing the **burner** to operate on high-fire. The **thermostat** is located on the front left side of the dryer. Observe the gas pressure on gauge, and turn the **thermostat** to its MINIMUM SETTING, causing the **burner** to cycle into low-fire. As the **burner thermostat** is turned down the gas pressure should also show a noticeable drop, indicating that the **high-fire solenoid** is closed and the **burner** is being supplied with less gas through the **low-fire control valve**. At this time set the high-

fire and low-fire pressure settings. Use the PRESSURE REGULATOR for high-fire and the BALL VALVE for low-fire. The **thermostat** should cycle between high and low, approximately 4 to 5 times per minute.

Approximate settings should be:

LP Gas	High-Fire 6-15 lbs.
	Low-Fire 2-6 lbs.
Natural Gas	High-Fire 6-10 lbs.
	Low-Fire 1-3 lbs.

If the **burner** remains on high-fire and does not cycle, INCREASE the regulator setting on the propane models, or the supply valve on the natural gas models in order to reach the **thermostat** setting. If the **burner** remains in low-fire and does not cycle, slightly DECREASE gas

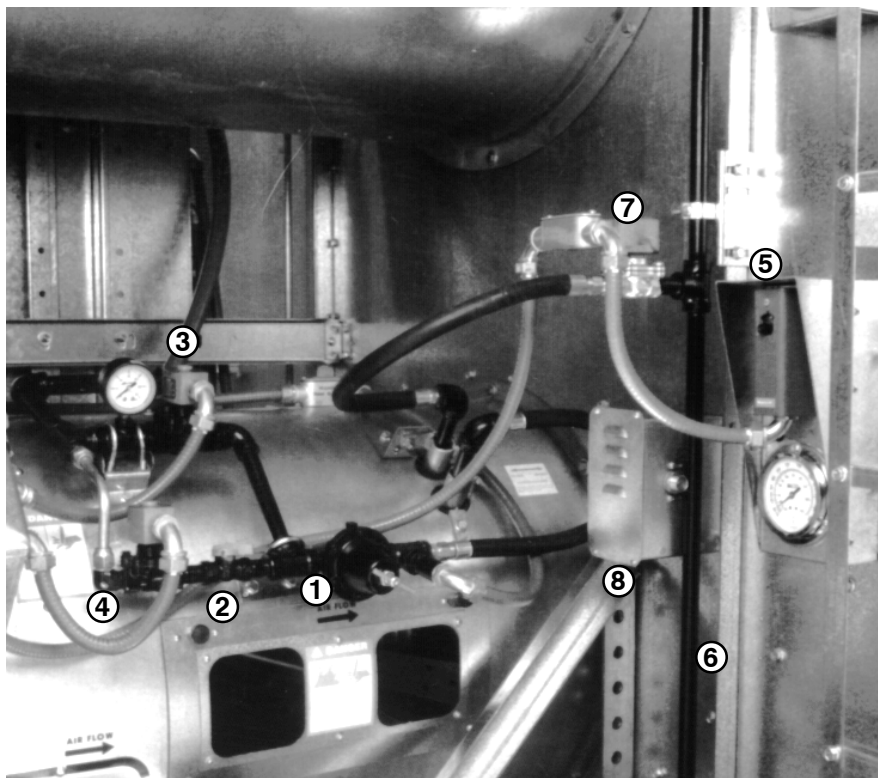

The dryer fan and heater controls featuring: 1-pressure regulator, 2-low-fire control valve, 3-high pressure solenoid, 4-low pressure solenoid, 5-high-low fire thermostat (assembly includes thermometer), 6-fuel supply line, 7-LP solenoid or supply ball valve(NG) and 8-air pressure switch.



## DRYER PRE START CHECKS



All dryer functions should be checked before operation each season.

pressure with the LOW-FIRE CONTROL VALVE. If the gas pressure is decreased too much a popping or fluttering sound will be heard. Also, anytime the high pressure side is adjusted the low pressure side needs to be checked.

### STAGED BATCH CHECK

To check the staged batch operation, turn the CONTROL POWER switch to the ON position. Press the RESET button, OPEN the main FUEL SUPPLY VALVE at the tank on an LP dryer or valve in the fuel supply line on a natural gas dryer. Turn the DRYING MODE switch to the STAGED BATCH position. Turn ON the electric SHUT OFF

VALVE to allow fuel flow to the dryer, if so equipped. Turn the LOAD switch to AUTO and UNLOAD switch to 1 SPEED. Push the DRYER POWER START button and the controller will sequentially start all dryer components in their proper order. If any switches are not in their correct position for staged batch operation, the dryer will indicate improper switch position, and will not start until the switches are in the proper position. After starting, all batch timers will time down in sequence. When the unload cycle is complete the timers will automatically reset to their original settings, and start the dry timer again.

### DRYER SHUTDOWN

To shutdown the dryer, first CLOSE the FUEL SUPPLY VALVE at the tank or valve along the fuel line. If the **burner** is operating, let the dryer run out of fuel, and it will shutdown automatically due to loss of flame. CLOSE the FUEL VALVE at the dryer, and press the DRYER POWER STOP button. Turn OFF the **safety disconnect handle** on the front of the **power box**, and turn OFF the main POWER to the dryer.

### EMERGENCY

In case of emergency push the dryer POWER STOP button. The **fan**, **burner** and all **augers** will stop immediately.

# DRYER START UP

## CONTINUOUS FLOW AND CONTINUOUS BATCH START UP PROCEDURE

At the beginning of each harvest and before filling the dryer with grain make sure to inspect the dryer for rodent damage, proper belt and chain tension and missing or damaged safety shields. Test operate the dryer using the prestart check procedures located on pages 14-17.

1. Before attempting to operate the dryer make sure that all **safety shields** are in place, all **plenum bottom closure panel doors** are closed, all **rear access doors** are closed and all personnel are clear of the grain dryer and grain handling machinery.
2. Turn all **SELECTOR** switches on the **control panel** to the OFF position.
3. Turn ON the electric **POWER** supply to the dryer, and move the **safety disconnect handle** mounted on the dryer's **upper power box** to ON.
4. Turn the **CONTROL POWER** switch to ON. The switch will light up. A copyright message, model number, total running time in hours and minutes, current date and time will appear. At this point the controller will lock out all other dryer functions. Once the date and time appear, press **RESET**, and the dryer will perform its safety circuit checks. If a fault is found the cause will

be displayed on the LCD. If all are found safe the controller will allow the electronic **FUEL SHUT OFF** valve to be manually **OPENED** (if so equipped), and the **DRYING MODE** switch will light up, indicating that the dryer is ready to be started.

5. Move the **LOAD AUGER** switch to **MANUAL**, and push the dryer **POWER START** switch. The **top auger** will immediately start, and the **LOAD AUGER** switch will light up. If additional grain handling equipment is wired to the dryer it will also start immediately.
6. When the dryer is full of grain the **top auger** will stop automatically, and any grain handling equipment wired to the dryer will also stop.

### CONTINUOUS FLOW OPERATION

1. Turn the **CONTROL POWER** switch to ON.
2. After the date and time appear on screen, press the **RESET** button.
3. Push the dryer **POWER START** switch.
4. **OPEN** the main **FUEL SUPPLY VALVE** on the tank if using LP gas, or **OPEN** the **FUEL SUPPLY LINE** if using natural gas.

Turn ON the electric **SHUTOFF**, **Maxon** valve (if so equipped), or **OPEN** the manual **SHUTOFF** valve to allow fuel flow to the dryer.

5. Turn the **DRYING MODE** switch to **CONTINUOUS FLOW**.
6. The dryer should already be filled with grain. Turn the **LOAD AUGER** switch to the **AUTO** position. In both the auto and manual positions the dryer grain level switch will automatically keep the dryer full of grain. In the auto position the dryer will shut down after a preset time period on the out of grain timer.
7. Turn the **FAN** switch to ON. The fan will start, and the switch will light up when airflow is detected.
8. Start the **burner** by turning the **HEATER** switch to ON. After purging for approximately 10 seconds the burner will fire, and the heater switch will light up. This indicates that the flame sensing circuit is sensing burner flame. For information concerning burner adjustment see the pre start section of this manual.
9. Operate the **heaters** to dry grain for 6-7 minutes per point of moisture to be removed with the plenum temperature set at 180°F. Example: Shelled corn starts with 25% moisture and

## DRYER START UP

the final moisture content is to be 15% (10% removal). Using the all heat dryeration process, the estimated drying time is 60 minutes (10 x 6).

10. While operating the dryer adjust the METERING ROLL dials to the recommended settings. See the chart on page 00.

11. To move grain through the dryer turn the MOISTURE CONTROL switch to ON. The switch will light up.

Note: When the UNLOAD switch is in the 2 SPEED position, and the MOISTURE CONTROL THERMOSTAT switch is OFF, the speed of the **metering rolls** can be manually adjusted by turning the HIGH SPEED METERING ROLL dial. Turning the dial clockwise will INCREASE the grain discharge rate, counterclockwise will DECREASE the discharge rate. (The numbers on the speed dials indicate the percentage of full speed.)

12. At the end of the start-up period, start the flow of grain out of the dryer. Turn the UNLOAD switch to the 2 SPEED position. The **bottom auger** and **metering roll** will immediately start, and the unload switch will light. If additional grain handling equipment is utilizing the unload auxiliary overload supplied with the dryer, this equipment will also immediately start.

13. To shut the dryer down, CLOSE the FUEL SUPPLY VALVE at the fuel tank or fuel source. Let the dryer run until the fuel supply lines drain, and the dryer automatically shuts down due to loss of flame. CLOSE the FUEL valve at the dryer. Press the DRYER POWER STOP button. Turn OFF the dryer's SAFETY DISCONNECT handle. Turn OFF the MAIN POWER supply to the dryer.

14. In case of emergency push the dryer STOP button. The **fan**, **burner** and all **augers** will stop immediately.

Note: The Electronic Monitoring Control System can be used to automatically start the dryer. Place all the control panel SELECTOR switches in the PROPER POSITION, and OPEN the electric FUEL SHUT OFF valve before PRESSING the DRYER POWER START button. The controller will start all dryer components in their proper order.

### STAGED BATCH OPERATION

1. Turn the CONTROL POWER switch to ON.
2. Make sure the DRYING MODE switch is turned to STAGED BATCH.
3. After the date and time appear, PRESS the RESET button.
4. OPEN the main FUEL SUPPLY VALVE on the tank if using LP

gas or the valve in the FUEL SUPPLY LINE if using natural gas. Turn ON the ELECTRIC SHUT OFF, Maxon valve (if so equipped), or OPEN the manual SHUT OFF valve to allow fuel flow to the dryer.

5. The dryer should already be filled with grain. Turn the LOAD AUGER switch to AUTO. In both the auto and manual position, the grain level switch will automatically keep the dryer full of grain. In the auto position, the dryer will shut down after the preset time period on the OUT OF GRAIN TIMER, or if the grain flow to the dryer is interrupted.
6. Turn the FAN switch to AUTO. The **fan** will start, and the switch will light up when airflow is detected.
7. Start the **burner** by turning the HEATER switch to AUTO. After purging for approximately 10 seconds the burner will fire, and the heater switch will light up indicating that the flame sensing circuit is sensing burner flame. For information concerning burner adjustment see the pre start section of this manual.
8. To properly set the correct dry, cool and unload time for various moisture content grains. See the chart on page 00.

## DRYER START UP

9. If the dryer is being operated in all heat, turn the FAN switch to ON. In this position the **fan** will run continuously during the dry, cool and unload stages of the staged batch operation. If the dryer is being operated in the dry and cool mode, the preferred position for the FAN switch is the ON position, so the **fan** will run continuously. If desired, the fan can be turned off during the unload cycle of the dry-cool-unload sequence by turning the FAN switch to AUTO.
10. If the dryer is being operated in all heat, turn the HEATER switch to ON. The **burner** will operate whenever the **fan** is operating. If the dryer is being used in dry and cool, turn the HEATER switch to AUTO and the **burner** will automatically shutdown during the cooling and unloading cycles.
11. Turn the UNLOAD switch to the 1 SPEED position. The **bottom auger** and **metering rolls** will start automatically during the unload cycle of the dry-cool-unload mode, along with any grain handling equipment that is wired to the dryer. The speed at which the **metering rolls** operate during the unload cycle is adjusted by using the HIGH SPEED METERING roll dial. Turning the dial clockwise will INCREASE the grain discharge rate, and counterclockwise will DECREASE the discharge rate.
12. To control the length of the dry cycle using only the dry time setting programmed into the system, turn the MOISTURE CONTROL setting to OFF. To use the automatic moisture control so that the dry time is determined, not only by the dry time setting, but also by the moisture content of the drying grain, turn the MOISTURE CONTROL switch to ON.
13. To start the drying operation push the dryer POWER START button. The controller will start all the dryer components in their proper order. If any of the selected switches are improperly positioned for staged batch drying, the display will indicate the proper switch position, and will not allow the dryer to operate until the position of the switch is corrected.
14. To shutdown the dryer, CLOSE the FUEL SUPPLY valve at the fuel tank or fuel source. If the **burner** is operating, let the dryer run out of fuel causing an automatic shutdown due to a loss of flame. CLOSE the FUEL VALVE at the dryer, and press the dryer POWER STOP button. Turn OFF the dryer's main CIRCUIT BREAKER located on the front of the power panel. Turn OFF the MAIN main POWER SUPPLY to the dryer.
15. In case of an emergency press the dryer POWER STOP button. The **burner**, **fan** and all **augers** will stop immediately.

### FAN & HEATER SWITCH SETTINGS

Fan Setting	Heater Setting	Fan Function	Heater Function
Auto	Auto	Fans stay on during dry and cool cycle only	Burners stay on during dry timer cycle only
Auto	On	Fans stay on during dry and cool cycle only	Burners stay on during dry and cool cycle only
On	On	Fans are on continuously	Burners are on continuously
On	Auto	Fans are on continuously	Burners shut down at the end of the dry cycle

At the end of the dry cycle in staged batch, the fans and heaters will continue running if in the Auto-Auto setting, until the preset temperature on the moisture control thermostat is reached.

# DRYER START UP

## I 100 SERIES BATCH TIMER SETTINGS

Initial Moisture	Moisture Removed	Full Heat Fan & Burner Switches on Manual				Dry & Cool Fans on Manual      Burners on Auto			
		Approx. Dry Time	Dry	Cool	Unload*	Approx. Dry Time	Dry	Cool	Unload*
17%	2 pts.	16 min.	6 min.	0	10 min.	18 min.	18 min.	18 min.	10 min.
18%	3 pts.	21 min.	11 min.	0	10 min.	24 min.	24 min.	18 min.	10 min.
19%	4 pts.	26 min.	16 min.	0	10 min.	30 min.	30 min.	18 min.	10 min.
20%	5 pts.	31.5 min.	21.5 min.	0	10 min.	35 min.	35 min.	18 min.	10 min.
21%	6 pts.	37 min.	27 min.	0	10 min.	40 min.	40 min.	18 min.	10 min.
22%	7 pts.	41.5 min.	31.5 min.	0	10 min.	45 min.	45 min.	18 min.	10 min.
23%	8 pts.	47 min.	37 min.	0	10 min.	50 min.	50 min.	18 min.	10 min.
24%	9 pts.	51 min.	47 min.	0	10 min.	55 min.	55 min.	18 min.	10 min.
25%	10 pts.	54 min.	44 min.	0	10 min.	60 min.	60 min.	18 min.	10 min.
26%	11 pts.	58 min.	48 min.	0	10 min.	65 min.	65 min.	18 min.	10 min.
27%	12 pts.	62 min.	52 min.	0	10 min.	70 min.	70 min.	18 min.	10 min.
28%	13 pts.	66.5 min.	56.5 min.	0	10 min.	75 min.	75 min.	18 min.	10 min.
29%	14 pts.	71.5 min.	61.5 min.	0	10 min.	80 min.	80 min.	18 min.	10 min.
30%	15 pts.	76 min.	66 min.	0	10 min.	85 min.	85 min.	18 min.	10 min.
31%	16 pts.	81 min.	71 min.	0	10 min.	90 min.	90 min.	18 min.	10 min.
32%	17 pts.	86 min.	76 min.	0	10 min.	95 min.	95 min.	18 min.	10 min.
33%	18 pts.	91 min.	81 min.	0	10 min.	100 min.	100 min.	18 min.	10 min.
34%	19 pts.	96 min.	86 min.	0	10 min.	105 min.	105 min.	18 min.	10 min.
35%	20 pts.	100 min.	90 min.	0	10 min.	110 min.	110 min.	18 min.	10 min.

These are approximate starting points.

\*Set unload metering roll high speed setting to 999. If unload equipment cannot adequately keep up, lower the speed setting and add time to the unload timer setting to completely unload the batch. In full heat mode, the time added to the unload timer will need to be subtracted from the dry timer. If fan is on auto and does not run during unload, set cool timer to 25 minutes.

$$\text{New unload time calculation} = \text{present unload time} \times \frac{\text{new dial setting}}{1000}$$

Example

$$13.75 = 11 \div \frac{800}{1000}$$

## QUICK START UP PROCEDURE

Standard electrical safety practices and codes should be used when working with a dryer. Refer to the National Electric Code Standard Handbook by the National Fire Protection Association. *A qualified electrician should make all wiring installations.*



**ALWAYS DISCONNECT  
AND LOCK OUT POWER  
BEFORE WORKING ON OR  
AROUND DRYER**

### FULL START UP CHECK

This start up procedure assumes the following:

1. That you have read and understand the dryer operation and service manual.
2. That you have taken special note of all safety precautions.
3. That all **safety shields** are in place.
4. That all **metering roll access doors** have been opened and all foreign objects have been removed.
5. That you have done a pre start up check out.
6. That all **motors** have been checked for proper rotation.
7. That all **heaters** have been test fired.
8. That the fuel has been turned ON at the tank.
9. That the electric power has been turned ON.
10. That the main DISCONNECT switch on the dryer is ON.
11. That you have wet grain in the wet holding bin.
12. That you know the incoming grain moisture.
13. That you have the dry grain take away equipment in place.
14. That you have the grain going to the proper bin.
15. That all SWITCHES have been set to the OFF position.
16. That the **load mercury switch box** is installed with the side stamped up, in the up position.

### FILLING THE DRYER

1. Turn the green CONTROL POWER switch to ON. It should light up, go through 4 screens and end with the time and date.
2. Turn the DRYING MODE switch to CONTINUOUS FLOW.
3. Push the RESET on the computer key pad to activate the computer.
4. Make sure the UNLOAD switch is in the OFF position.
5. Push the DRYER POWER start switch, it should light up.
6. Turn the LOAD AUGER switch to the MANUAL position to fill the dryer. The **load auger** should start and run until the dryer is full, then shut off automatically. (If the switch is set to the auto position the dryer will shut down each time the out of grain timer times out, and will have to be restarted.)
7. When the dryer has filled, turn the LOAD AUGER switch to the AUTO position.

# QUICK START UP PROCEDURE

## STARTING THE DRYER

This start up procedure is for a cold start on wet grain for continuous flow operation.

1. Set the MAXON or FAST ACTION HAND VALVE on the incoming **fuel line** to the ON position.
2. Make sure the MOISTURE CONTROL switch is in the OFF position.
3. Turn the FAN switch (or switches if a multi-fan dryer) to the ON position. The light in the switch should light when the **fan** comes up to about half speed.
4. Adjust the PLENUM AIR PRESSURE switch if necessary. Use a flat blade screwdriver counterclockwise to make it more sensitive (taking less pressure to activate it), or clockwise for the opposite effect.
5. Turn the HEATER switch (or switches if a multi-fan dryer) to the ON position. The **heater** will purge for about 10 seconds then ignite. The light in the heater switch will come on during ignition and will stay on if the heater ignites. If the heater does not ignite, the light will go out after a trial for ignition and the dryer will shut down, indicating that it did not light. If this happens check gas supply, and all valves in the fuel line to make sure they are on.

## ADJUSTING THE TEMPERATURE

1. Set the HIGH-LOW FIRE PLENUM THERMOSTAT on the left side of the dryer to the drying temperature that you want to run (180° to 200°). On multiple module dryers set the plenum chambers 30° to 60° apart. Hottest at the top, most cool at the bottom.
2. On LP gas models adjust the PRESSURE REGULATOR (high fire) on the **burner fuel line**, so that burner will reach the thermostat setting and switch to (low fire) (pressures may be required up to 25 lbs.). Natural gas does not have a regulator, but uses a LARGE BALL VALVE close to the vertical supply line for adjustment (pressures may be required up to 18 lbs.).

On LP gas models adjust the small RED HANDLED BALL VALVE (low fire) so that the **burner** maintains flame then switches back to (high fire). Natural gas has a BALL VALVE close to the **burner control box**, for low fire adjustment.
3. Adjust the **burner** pressure so that the burners cycles 4 times per minute (approx. 10 sec. on high--approx. 5 sec. on low). When on high fire increasing the pressure with the PRESSURE REGULATOR DECREASES the time spent on high fire. When on low fire increasing the low fire pressure with the RED BALL VALVE INCREASES the time spent on low fire.
4. On LP gas models adjust the VAPORIZER so the **fuel pipes** going to

**How much gas pressure do I use?** See step number two in the *Adjusting The Temperature* section.

**How often should my burner cycle?** See step number three in the *Adjusting The Temperature* section.

## QUICK START UP PROCEDURE

the burner from the regulator are warm to the touch (not hot and cold).

The **vaporizer** can be adjusted two ways:

- Loosen the **bolt** in the hinging mechanism and swing it to a hotter or cooler position, or
- Loosen the **two bolts** in the hinge pipe and slide the **vaporizer** in or out to a cooler or hotter position.

Either one or both methods may have to be used to get the vaporizer to the proper temperature. Natural gas does not use a vaporizer.

**How often do I make speed adjustment?** See step number ten in the *Full Heat-Continuous Flow Operation* section.

### FULL HEAT-CONTINUOUS FLOW OPERATION

1. Check the Continuous Flow Metering Roll Settings-Full Heat on page 25. Pick the line that has your initial starting moisture. These are the settings we will be referring to during this start up procedure.
2. Make sure the UNLOAD switch is OFF.
3. Make sure the MOISTURE CONTROL switch is OFF.
4. Run the **fan(s)** and **heater(s)** for about 10% longer than the approximate drying time required for the moisture you are trying to dry.
5. Example: 10% removal would be about 54 minutes, 15% removal would be about 76 minutes and 20% removal would be about 100 minutes. Add 10 minutes to insure that the grain is dry.
6. After the time in step 4 turn the UNLOAD to 1 SPEED and set the METERING ROLL SPEED, HIGH SPEED potentiometer to the setting for 1 SPEED operation. Grain should begin to run at this time. Run time for this is about 10% longer than the approximate drying time required for the moisture you are trying to dry, as shown in the example #5 above. This allows the moisture in the dryer to reach an even gradient top to bottom without having any highs or lows in it. It will, however, overdry some of the corn a little.
7. Increase the drying temperature to 190° for single fans or for multiple fan dryers set the heat chambers 30° to 60° apart. Hottest at the top, most cool at the bottom.
8. DO NOT TRY TO ADJUST THE DRYER FOR MOISTURE DURING THIS PROCESS OR YOU WILL ESTABLISH HIGH AND LOW SWINGS IN THE MOISTURE CONTROL. IT WILL TAKE SEVERAL HOURS TO WORK ITSELF OUT.
9. After the run time in step 6 you are ready to set up the moisture control. Now turn the MOISTURE CONTROL to the ON position. Set the temperature to about 100°.
10. Turn the UNLOAD to 2 SPEED. Set the METERING ROLL SPEED, LOW SPEED and HIGH SPEED potentiometer to the settings listed for them. Let the dryer run on these settings as shown in the example #5 before trying to adjust moisture or meter roll settings. These settings



## QUICK START UP PROCEDURE

will not have your grain moisture adjusted exactly where you want it, but will be a good place to start initially. A little different moisture at the bottom of the storage bin is not usually a problem as long as you have full floor aeration.

11. After the run time in step 10 you are ready to adjust the moisture control, and the meter roll speeds if required. Each time you make an adjustment to the moisture control, it will take the approximate time shown in example #5 to see the results.

### I 100 SERIES CONTINUOUS FLOW METERING ROLL SETTINGS

Initial Moisture	Moisture Removed	Full Heat			
		Approx. Dry Time	1 Speed	2 Speed Low	2 Speed High
17%	2 pts.	16 min.	625	317	875
18%	3 pts.	21 min.	476	270	775
19%	4 pts.	26 min.	385	241	675
20%	5 pts.	31.5 min.	317	213	575
21%	6 pts.	37 min.	270	196	476
22%	7 pts.	41.5 min.	241	185	385
23%	8 pts.	47 min.	213	172	317
24%	9 pts.	51 min.	196	161	270
25%	10 pts.	54 min.	185	150	241
26%	11 pts.	58 min.	172	140	213
27%	12 pts.	62 min.	161	132	196
28%	13 pts.	66.5 min.	150	123	185
29%	14 pts.	71.5 min.	140	116	172
30%	15 pts.	76 min.	132	110	161
31%	16 pts.	81 min.	123	104	150
32%	17 pts.	86 min.	116	100	140
33%	18 pts.	91 min.	110	096	132
34%	19 pts.	96 min.	104	087	123
35%	20 pts.	100 min.	100	082	116

These are approximate starting points.

## QUICK START UP PROCEDURE

**How do I set my moisture control?** See step number one in the *Adjusting The Moisture Control* section.

### ADJUSTING THE MOISTURE CONTROL

1. Each 5° on the MOISTURE CONTROL changes the output moisture by about 1%. Example: 100° is set, producing 16% corn out, however, 17% corn out is needed. Reduce the MOISTURE CONTROL temperature by 5° to 95°. This should change the moisture out to about 17%. To make the corn come out dryer, raise the temperature on the MOISTURE CONTROL.
2. There are 4 sensors that are averaged together for sensing MOISTURE CONTROL temperature, 1 on each side of the dryer in the front, and 1 on each side of the dryer in the back. They are located about 1/3 of the way up the grain column from the bottom, and in from the side about 4 inches.
3. The small lights behind the temperatures on the MOISTURE CONTROL indicate the temperature of the grain at this sample point.
4. The 2 lights in the center are green, the lights to the right or to the left of these are red.
5. When the grain temperature has the dryer cycling HIGH and LOW speed on the green lights the moisture setting is being maintained correctly.
6. Set the METERING ROLL SPEED in relation to the small red lights behind the temperatures on the MOISTURE CONTROL.
7. Red lights to the left indicate that the grain at the sample point is too cool or wetter than desired. With this condition turn the LOW SPEED left potentiometer to a lower number. This will slow down the metering rolls and dry the grain longer, warming it up.
8. Red lights to the right indicate that the grain at the sample point is too hot or dryer than desired. With this condition turn the HIGH SPEED right potentiometer to a higher number. This will speed up the metering rolls and remove the grain quicker, cooling it down.
9. If the MOISTURE CONTROL switches to LOW and only stays on low for a minute or two and switches back to HIGH, speed up the LOW SPEED left potentiometer. It is set too slow.
10. If the MOISTURE CONTROL switches to HIGH and only stays on high for a minute or two and switches back to LOW, slow down the HIGH SPEED right potentiometer. It is set too fast.
11. The MOISTURE CONTROL should stay on HIGH about 50% of the time and on LOW about 50%, give or take 25%. There is a broad range that will work. It should be switching low to high and back to maintain the desired moisture. A control that does not switch, will not maintain an evenly dried grain moisture, when the incoming wet grain moisture is varying.
12. When adjusting the metering roll speeds it is better not to change the speed more than 20 points at a time.

# QUICK START UP PROCEDURE

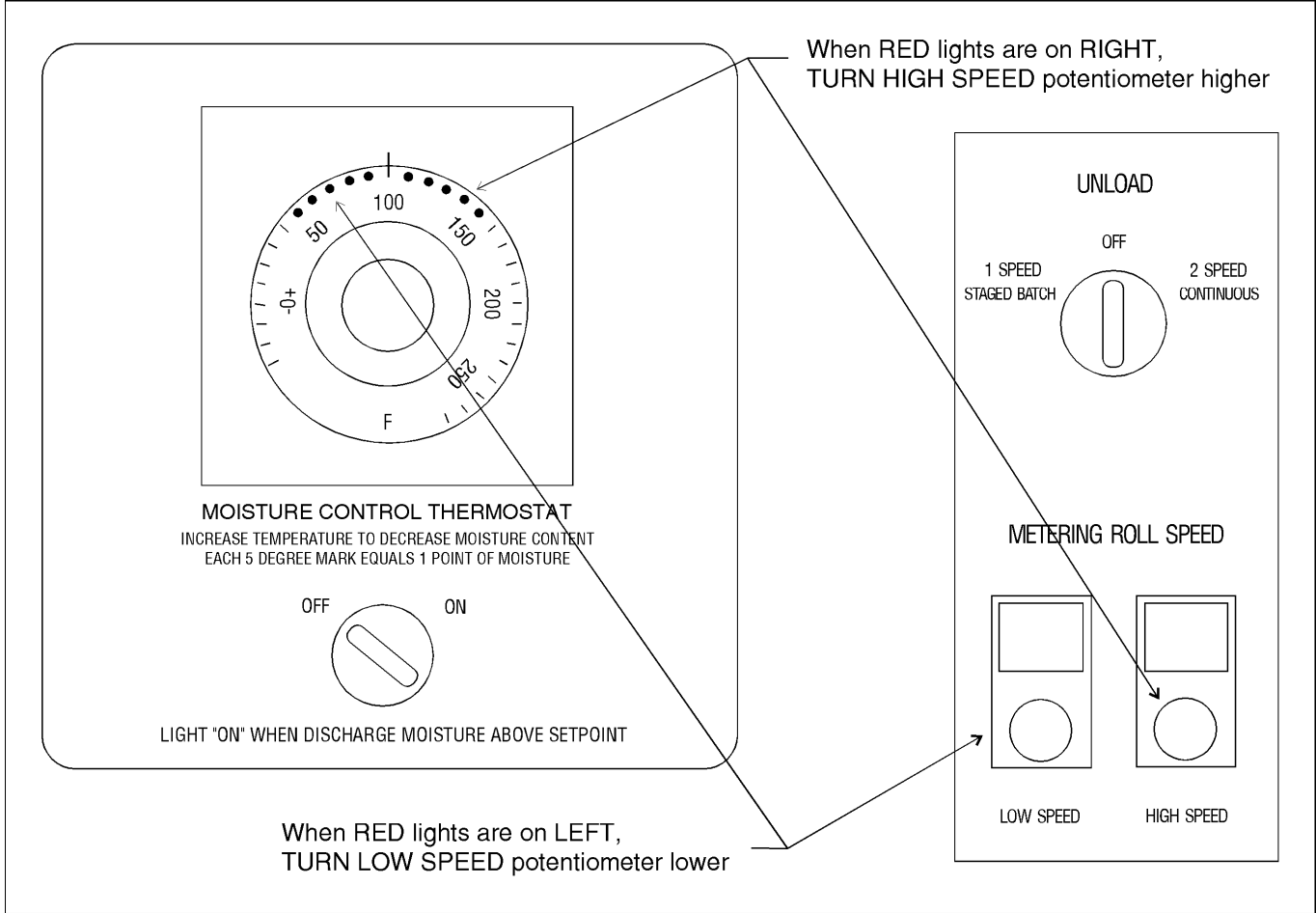

**I 100 SERIES SERVICE GUIDE**



# SERVICE

## SEASONAL INSPECTION AND SERVICE

The dryer is made of weather resistant material, and is designed to require a minimum of service. However, each season we recommend the following items be checked before the unit is used, and any damaged or questionable parts replaced. These checks will help eliminate possible failures, and assure dependable operation of the equipment.

1. SHUTOFF electrical power. OPEN **power box** and **control box**, and inspect for moisture, rodent damage or accumulated foreign material. Remove any foreign material present. Inspect and tighten any loose terminal connections. Replace any damaged or deteriorated wiring.
2. CHECK **propellor** for freedom of rotation and uniform tip clearance. It should also be inspected for dirt and grain dust, especially inside the hub. Any additional weight can seriously

effect the balance, and result in harmful vibrations and a short bearing life.

3. CHECK **propellor** for free play. Any side play is an indication of defective **motor bearings**, which should be replaced to prevent a complete motor failure. Make sure motor mount bolts are tight.
4. **Motor bearings** should be LUBRICATED periodically, depending on operating conditions. Under normal usage it is desirable to have the motor cleaned, checked and bearings repacked by an authorized service station every two to three seasons. If the unit is operated continuously through most of the year, this service should be performed each year.

Note: If on site bearing relubrication is to be performed, see lubrication instructions for ball bearing motors.

To keep motor bearings properly lubricated, and dispel any accumulation of moisture within the windings, the **fan** and **auger motors** should be operated for 15 to 30 minutes each month.

### LUBE PROCEDURES

If the **motor** is equipped with an **alemite fitting**, CLEAN the tip of the fitting and apply grease gun. Use 1 or 2 full strokes on motors in NEMA 215 frame and smaller. Use 2 to 3 strokes on NEMA 254 through NEMA 365 frame. Use 3 to 4 strokes on NEMA 404 frames and larger.

On **motors** equipped with **slotted head grease screw**, remove screw and apply grease tube to hole. Insert 2 to 3 inch length of grease string into each hole on motors in NEMA frame and smaller. Insert 3 to 5 inch length on larger motors. On **motors** having **grease drain plugs**, remove plug and operate motor for 20 minutes before replacing drain plug.

## LUBRICATION INSTRUCTIONS FOR BALL BEARING MOTORS SUGGESTED LUBRICATION INTERVALS\*

Hours of Service per Year	H. P. Range	Suggested Lube Interval
5000	1/8 to 7 1/2 10 to 40 50 to 150	5 years 3 years 1 year
Continuous Normal Applications	1/8 to 7 1/2 10 to 40 50 to 150	1 year 3 years 9 months
Seasonal Service (motor is idle for 6 months or more)	All	1 year-beginning of season
Continuous high ambient temperatures, dirty or moist locations, high vibrations or when shaft end gets hot	1/8 to 40 50 to 150	6 months 3 months

\* The bearings have been lubricated at the factory, thus no lubrication should be added before start up.

# SERVICE

## SUGGESTED LUBRICANTS

Insulation Class	Consistency	Type	Grease	Frame Type
A & B	Medium	Polyurea	Shell Dolium R	215T & Smaller
A & B	Medium	Polyurea	Shell Dolium R	254 & Larger
F & H	Medium	Polyurea	Shell Dolium R	All

Note: All of the **auger** and **metering roll bearings** are lifetime lubricated and do not require service relubrication.

1. Remove and CLEAN the **gas line strainers**. Make certain **gas valves** are CLOSED and that gas is purged from the system before attempting disassembly.
2. Inspect the **collector plate** (at the top of the burner casting) and the **burner cup** for any accumulation of foreign material. CLEAN if required. Foreign material in the burner cup or casting will not burn out and will impair burner operation.
3. If required, inspect **ignitor plug** and CLEAN the **electrodes**. Use an ignition point file to remove

carbon and rust between the **electrode surfaces**. **Ignitor gap** should be about 1/8 inch.

4. Inspect **flame sensor** for possible damage or poor connections. **Flame sensor wire** must be in good condition.
5. Inspect and manually ROTATE the **top auger paddle assembly**. The paddle unit must rotate freely without any indication of sticking or binding.
6. Inspect the **top auger** and **bottom auger drive lines** for proper adjustment and condition. Readjust line tension as required.

Note: All of the **auger** and **metering roll bearings** are lifetime lubricated and do not require service relubrication.

7. OPERATE dryer **clean out levers**, and CHECK **clean-out hatch** mechanism for proper operation. With hatch open, inspect and remove any accumulation of dirt, fines and foreign material from the **bottom auger trough** area.

Note: Do not allow high moisture material to collect within the trough area. It may adversely affect metal parts.

8. Inspect entire dryer for loose, worn or damaged parts. Include CHECK of **auger fighting**, **metering rolls** and other internal parts. CHECK that **temperature sensors** within air plenum chamber are secured within insulated clamps, and do not chafe on other metal parts.
9. Make sure all **dryer guards** and **warning decals** are securely installed. Guards should not interfere with moving parts. If guards or warning decals are missing, contact your dealer for a free replacement.

10. TEST FIRE the **dryer** several weeks ahead of the drying season. CHECK for possible **gas** leaks. (See page 16 for burner test fire.)

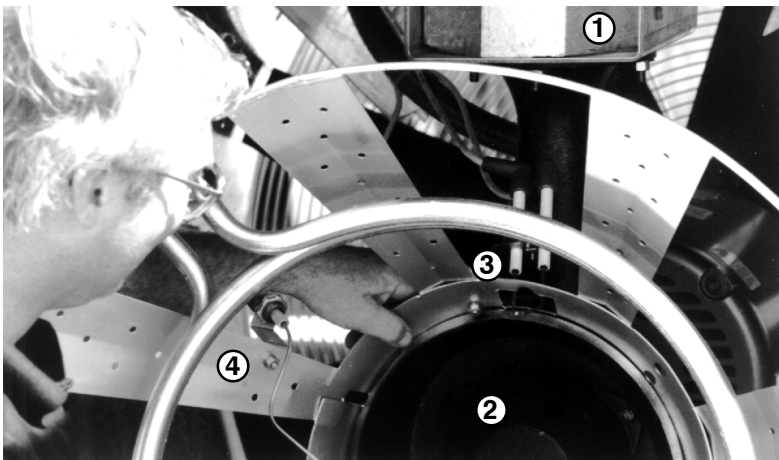

Remove the Blue Burn Optimizer Cone. Inspect 1-collector plate, 2-burner cup, 3-ignitor plug and electrodes and 4-flame sensor on the heater.

## FAN PROPELLOR REMOVAL AND INSTALLATION

The fan propellor is secured to the motor shaft by the use of a taper-lock bushing, motor shaft key and three cap screws.

**CAUTION:** Although the taper-lock method of retaining the propellor onto the motor shaft is simple, it is essential that the following points be read carefully and fully understood. *Improper installation can cause a loose flying propellor, and result in serious injury or death.*

### THREADED BUSHING HOLES

The threaded holes within the bushing are provided for disassembly purposes only. Do not attempt to use these holes for reassembly. *They will not allow the parts to lock onto the shaft thereby causing a hazardous operating condition.*

### CLEARANCE HOLES

When reassembling parts, the cap screws must be installed through the untapped clearance holes as shown. This will cause the propellor to be pulled forward onto the tapered bushing, thus locking the parts securely onto the motor shaft.

When fan servicing requires removal and installation of the propellor, make sure the propellor is removed and reinstalled properly.

1. LOCK OUT the fan power supply, and REMOVE the fan guard and the venturi, as required on some models.

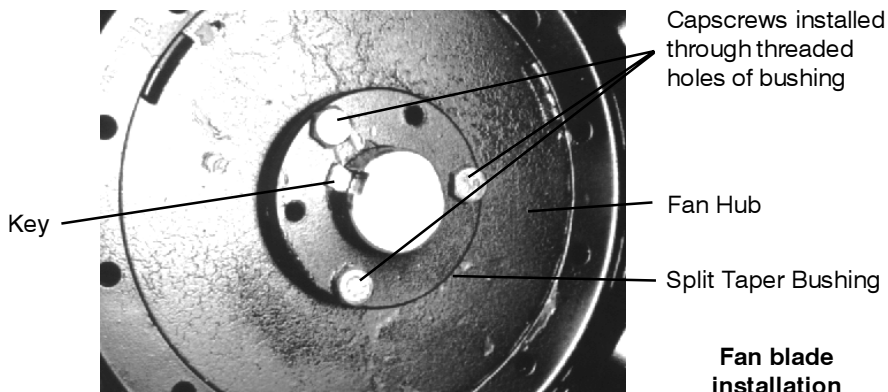

2. REMOVE the three cap screws from the clearance holes in the taper-lock bushing.
3. INSTALL two grade 5 cap screws into the threaded holes in bushing. TURN caps by hand until they bottom against the front surface of the propellor.
4. BLOCK propellor to prevent it from turning, and gradually TURN the cap screws (up to 1/4 turn at a time) until the propellor breaks loose from the bushing and motor shaft. Carefully REMOVE bushing and propellor. With the propellor free from the bushing, a wheel can be used to PULL the bushing off of the motor shaft. REATTACH bush-

ing onto propellor to prevent the loss of parts.

Note: During manufacture the propellor and bushing on the 26" and 28" solid aluminum blades are balanced together, and are marked with two small dots to identify their original alignment position. CHECK the bushing and propellor to make sure they have alignment marks. MARK the alignment of the propellor and bushing, if necessary.

Crowley blades have a keyway to prevent any misalignment of the propellor and bushing. Alignment marks are on the back of the fan hub assembly. To replace one of the blade fins, alignment would be necessary, however, this is not recommended. In most cases, the complete propellor should be changed.

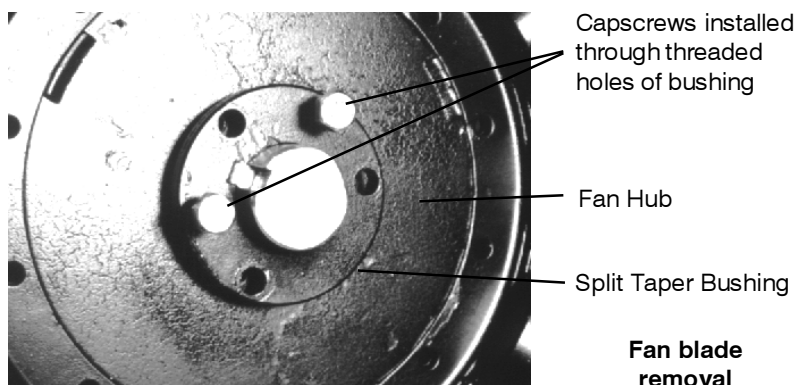

## SERVICE

### FAN MOTOR REMOVAL AND INSTALLATION

In the event of motor failure, remove the motor as described, and take it to the nearest service station. *An authorized service station is the only place that can provide possible motor warranty.* Motor service and repair at other places will be at owner's expense.

If the service station determines motor failure is caused by faulty material or workmanship within the warranty period, repair will be covered under the warranty. Motor failure caused by external sources will result in a charge to the owner for repair.

1. Make certain power is SHUT-OFF and locked out. REMOVE **fan guard** and **propellor**.
2. REMOVE cover from **fan/heater control box**, and DISCONNECT

the **motor lead wires** from within the box.

Note: Tag or otherwise identify wires for ease of reassembly.

3. REMOVE **motor mount bolts**. If there are shims between the motor and its base, note their location so they can be properly installed during reassembly.
4. DISCONNECT the upper end of the **motor conduit**, and carefully PULL the **wires** through the hole in the **fan/heater housing**. REMOVE **motor** from the **fan/heater unit** with the **conduit** still attached. If motor requires service, take it to an authorized service station.
5. To reinstall **motor**, SLIDE onto motor **base plate** and REPLACE

shims (if required) between **motor base** and **plate**. REINSTALL **motor mount bolts** and **washer**. Do not fully tighten at this time.

6. REINSTALL **conduit** and **wires** through hole in **fan/heater housing** and carefully CONNECT all **electrical wiring**.
7. ADJUST position of **motor**. Temporarily MOUNT **fan blade** on **motor shaft**. ROTATE **fan blade** by hand, making the necessary adjustments, so the tip clearance between blade and housing is uniform. If required, REMOVE the **fan blade** and fully TIGHTEN all four **motor mount bolts**.

Note: Make sure to INSTALL and TIGHTEN the **propellor** in accordance with previous instructions.

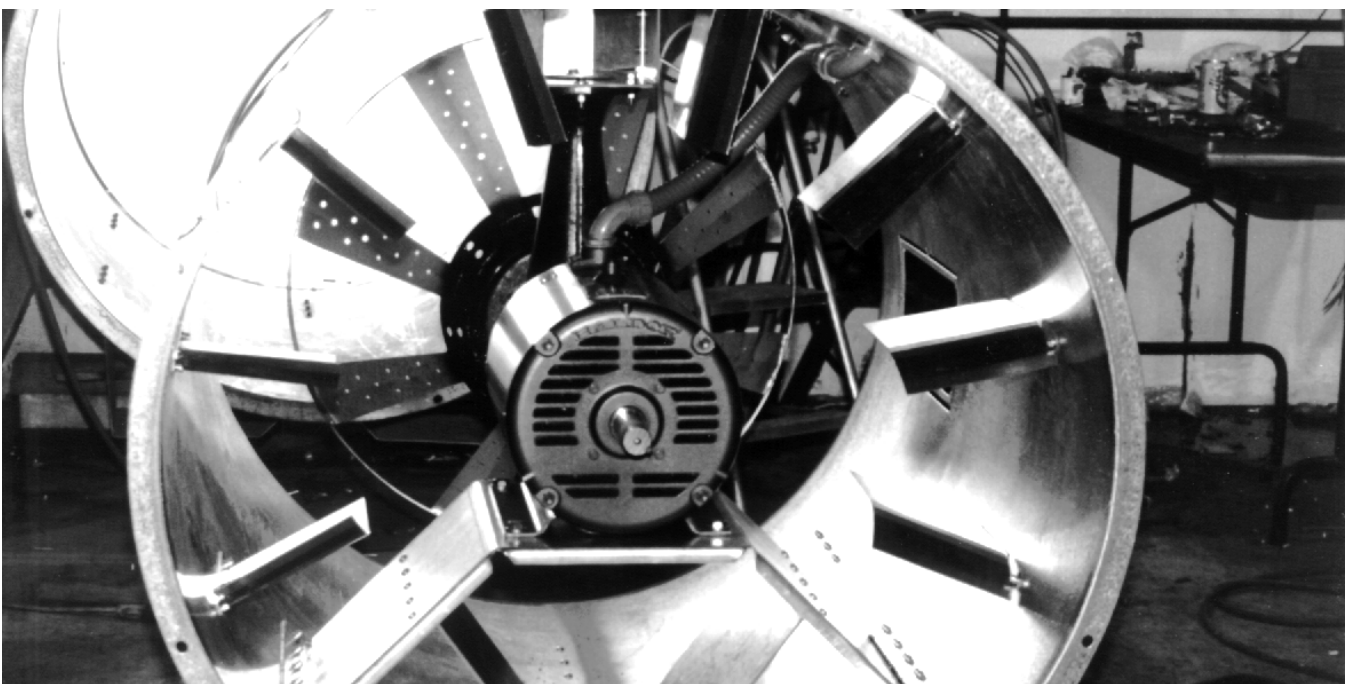

The position of the fan motor provides easy access for service.



## HEATER PARTS REMOVAL AND INSTALLATION

Most heater parts can be removed by simply identifying any attached **wiring**. Then DISCONNECT the obvious mounting parts.

1. **Flame sensor:** DISCONNECT the **wire connector**. UNSCREW the **flame sensor** out of its mounting bracket.

2. **Gas Solenoid valve coil:** UNSNAP either the plastic cap, or the metal clip on the **gas valve**, and SLIDE the housing and coil off the valve stem and body. Do not energize the coil when it is removed, as the coil may become damaged due to excessive current flow.

3. **Regulator and gas solenoid valve(s):** The gas regulator and solenoid valve(s) are directional and must be connected as indicated by the markings near the port openings. Make sure gas is shut off and purged from the system before removing parts.

Note: When installing a liquid gas solenoid valve on LP models, do not over tighten the connection into the inlet side, as the inlet orifice may become partially blocked.

4. **Main Gas Orifice:** With fuel shut off and gas purged from system, proceed as follows:

a. Disconnect the plumbing support brackets from the pipe train.

b. Disconnect gas solenoid valve coils. Be sure to mark which one goes where.

c. Lift pipe (with orifice, solenoid valve and other parts attached), straight up and remove from fan heater housing. Orifice and other parts can now be removed from pipe train, if desired.

5. **Reassemble:** To reassemble parts, reverse the disassembly procedure and check the following:

a. Make sure all parts are thoroughly cleaned and open.

b. Use a dependable brand of high temperature pipe caulking compound when assembling gas connections. Apply only a light coating onto male threaded end of fittings.

c. Solenoid valves and gas regulators are directional and must be properly installed. Do not attempt to connect gas solenoid valve by applying force to the valve core stem as it may ruin the unit.

d. Make sure all electrical wires are properly connected. Refer to wiring diagrams.

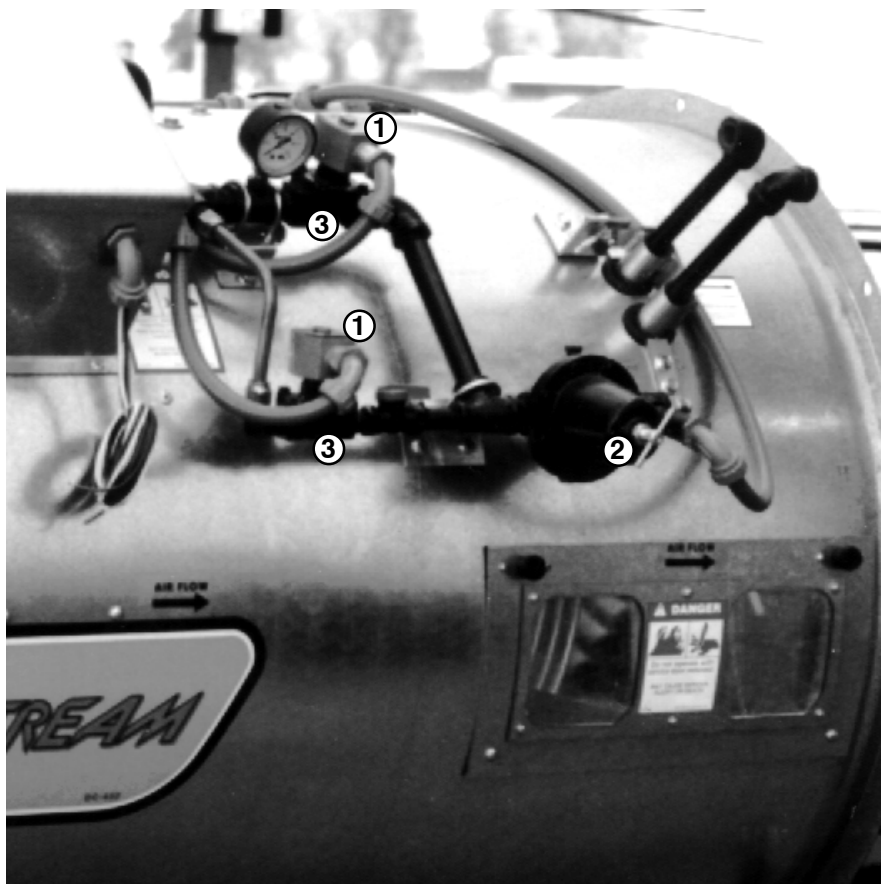

This view of the dryer heater shows 1-gas solenoid valve coils and 2-gas regulator and 3-gas solenoid valves.

## METERING ROLL SERVICING

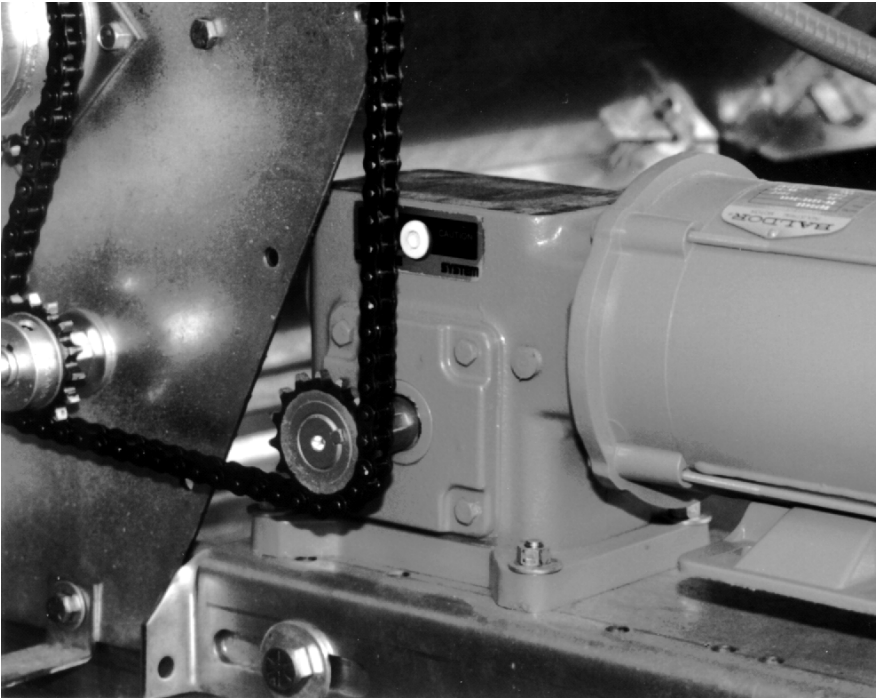

The speed reducer gear box.

This dryer is equipped with SCR metering roll drive assembly. The metering rolls are driven by a separate DC type electric motor. The speed of the motor is variable and is controlled by an electric SCR (silicon controlled rectifier) control within the main control box.

### MAIN CONTROLS

1. **SCR speed control:** The control unit dial on the front of the control box regulates the speed of the DC motor which drives the metering rolls.

The markings on the scale from 0 to 999 represent the flow of grain past the metering rolls as a percent of the maximum grain discharge rate for the dryer. The maximum setting of 999 provides a maximum 100% dis-

charge of 1120 BPH for 1108, 1400 BPH for 1110, 1680 BPH for 1112, 1960 BPH for 1114, 2240 BPH for 1116, 2520 BPH for 1118, 2800 BPH for 1120, 3080 BPH for 1122 and 3640 BPH for 1126 model dryers.

**Note:** When the control is set to the maximum discharge rate (999), the metering roll speed should be 9.75 RPM for 6" discharge and 17.5 RPM for 8" discharge auger.

2. **DC electric motor:** The direct current (DC) motor provides the drive for the metering roll, and is located on the front left hand side of standard model dryers. The output shaft of the motor is connected directly to the gear box assembly.

The DC motor requires no opera-

tional adjustment as it is completely controlled from the control box.

3. **Speed reducer gear box:** The direct drive gear box provides the required speed reduction, and transmits power to the metering rolls through a drive chain arrangement. The gear box does not require adjustment. The drive chain should also be periodically lubricated and retensioned as necessary.
4. **Unload auger time delay:** The delay controls the bottom auger system and causes the unload auger (and any connected auxiliary unloading conveyors) to continue operating for the programmed amount of time, even after the metering rolls stop. This feature permits the cleanout of grain within the unloading equipment at the end of all discharge cycles.
5. If a foreign object becomes lodged in the metering rolls and jams the system, the following events will occur. The unloading auger will stay in motion. However, the metering roll drive will stop and the DC motor should stall out. The Electronic Monitoring Control System will shut down the dryer after a two minute period. If any one metering roll or sensor should malfunction the control will display a left or right metering roll failure warning.

## HOW TO DETERMINE A METERING ROLL PROBLEM

To determine if the metering problem is from blockage, perform the following test with the power off. Remove the drive chain by loosening the motor mounting bolts. Refer to photo, and place a pipe wrench on the hub of the roller chain sprocket, on the left hand metering roll at the drive end of the dryer. Apply up to 100 ft. lbs. of force, and attempt to rotate the roll toward the inside of the dryer. If the metering roll will turn, then repeat for right hand side. If metering roll will turn, it can be assumed that no blockage exists, and the problem is from some other cause. Check for a break in the power train, chain, drive key, pin, etc.

**CAUTION: Keep hands away from sprocket teeth to avoid injury from chain backlash, as a result of torsion build up in the system caused by the jam.**

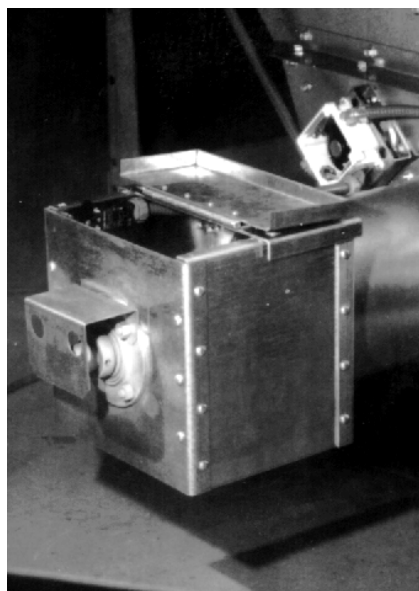

The auger discharge switch.

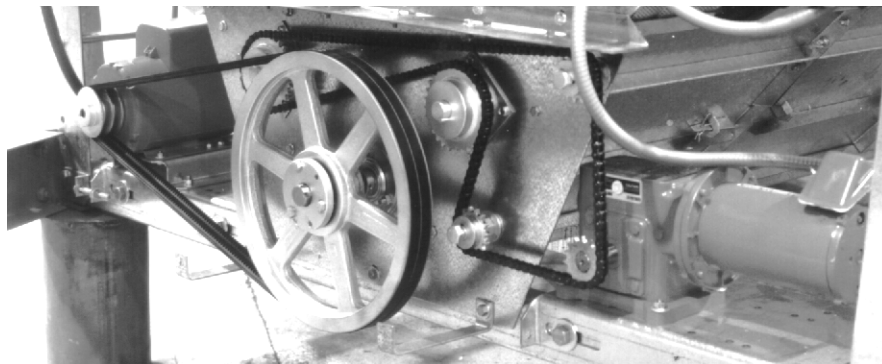

The metering roll drive.

## HOW TO CLEAR A JAMMED METERING ROLL

Place a pipe wrench on the hub of the sprocket of the jammed metering roll and turn the roll. First backward, and then forward several times in an attempt to dislodge the object, and clear it through the roll. If this is not successful, have an assistant turn the metering roll, and attempt to locate the jam by sound. Shut down the fan heater and eliminate any other

noise when making this check. Once the location is determined, the roll can be reached from the outside by opening the access door to remove the foreign object causing the jam (before opening doors see below). The service tool must be inserted before opening doors. First, swing open the plenum bottom closure panel. Insert service tool above metering roll.

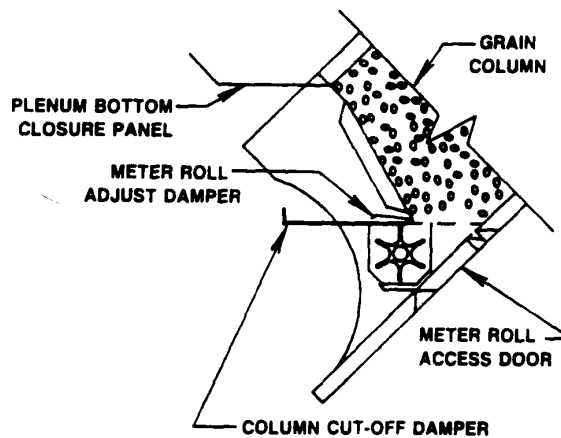

### SERVICE TOOL

This column cutoff damper is designed to insert through the grain column (from the inside of the dryer) immediately above the metering roll. This permits opening of the metering roll access door. For service or inspection without unloading the dryer, the plenum bottom closure panel and metering roll adjust damper must be removed prior to using service tool.

# SERVICE

## INPUT/OUTPUT BOARD TERMINAL IDENTIFICATION

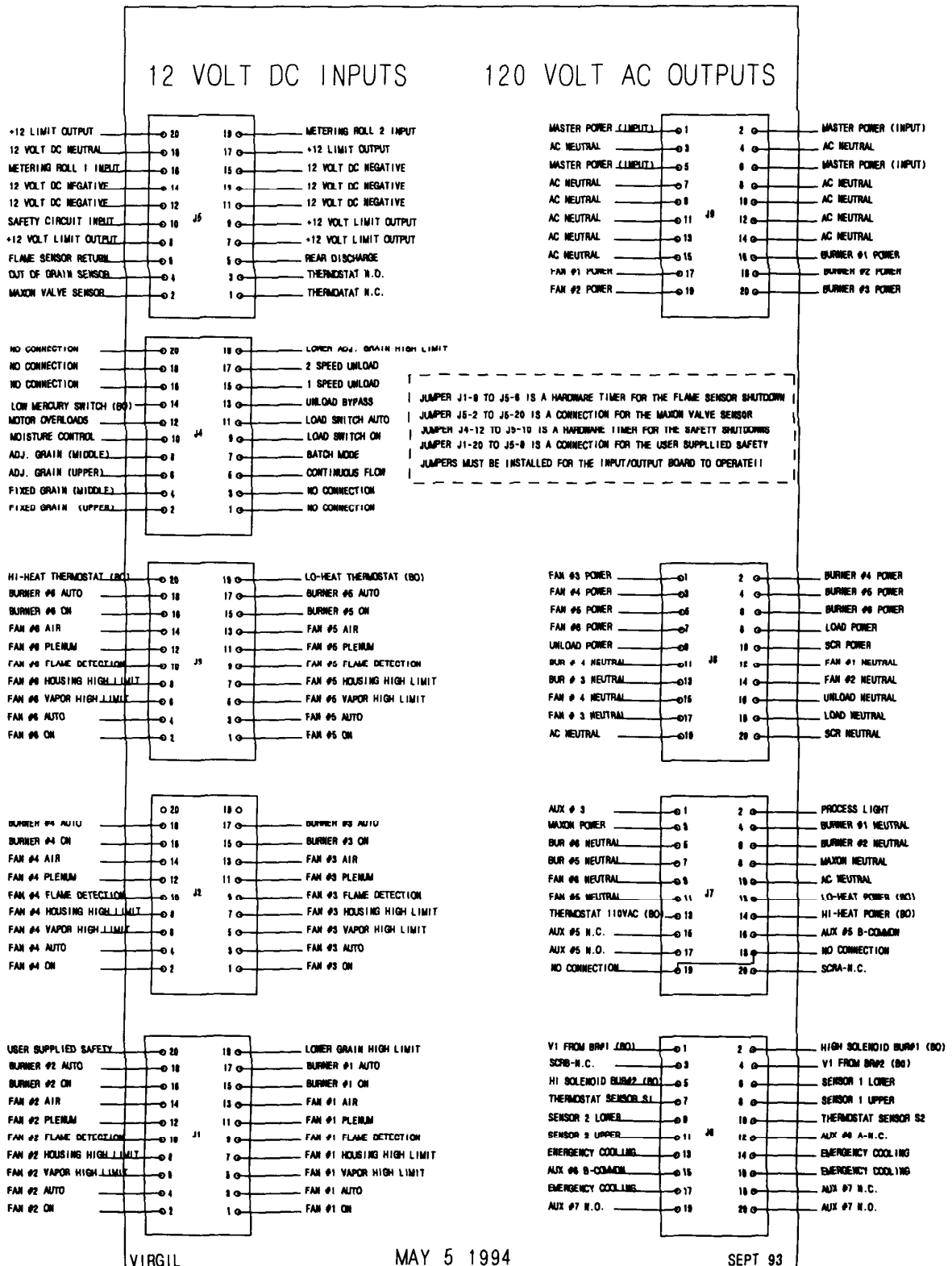

VIRGIL

MAY 5 1994

SEPT 93

# SERVICE

## I 100 SERIES SINGLE FAN WIRING TO CONTROL BOX

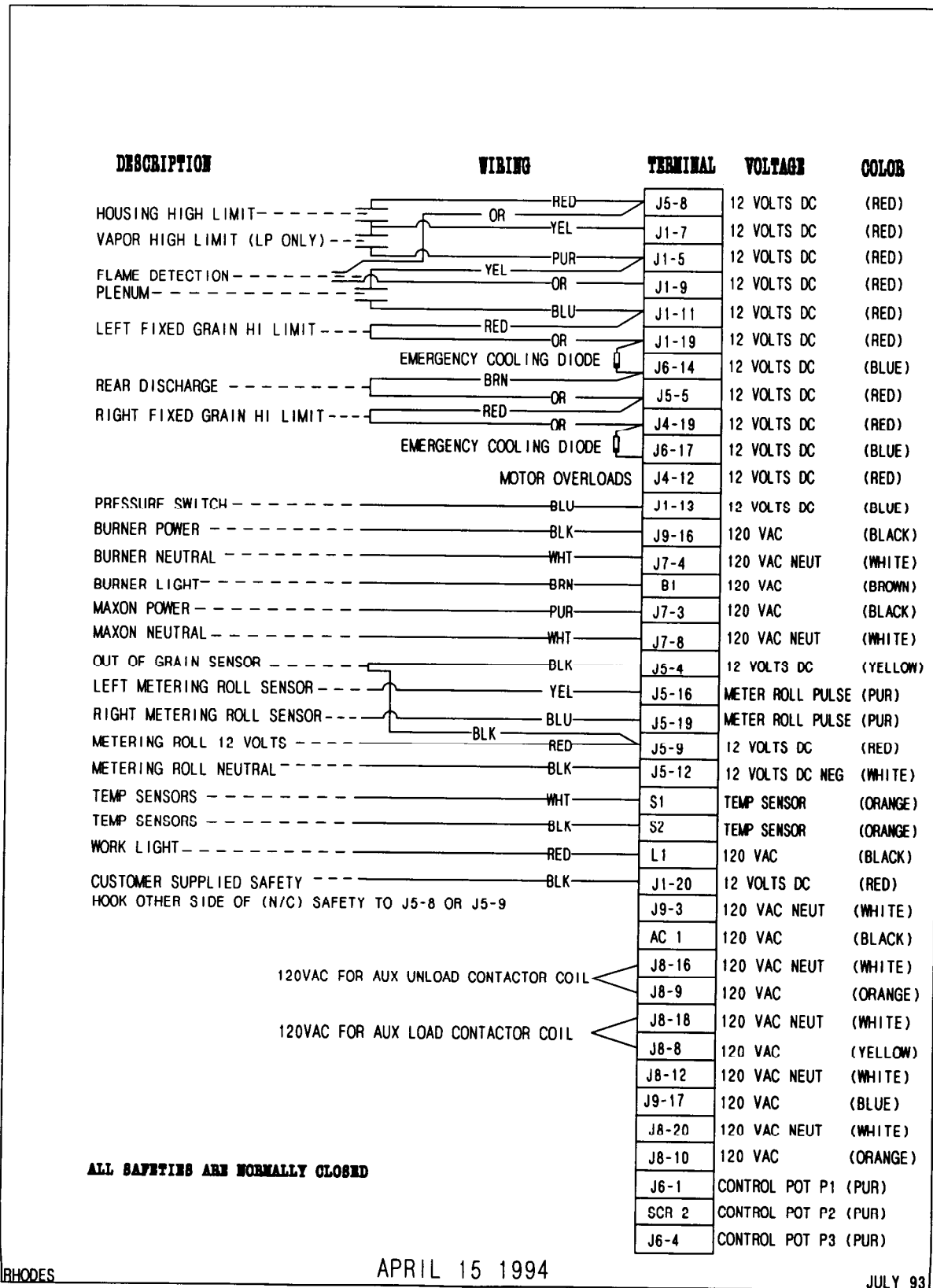

# SERVICE

## I 100 SERIES CONTROL WIRING

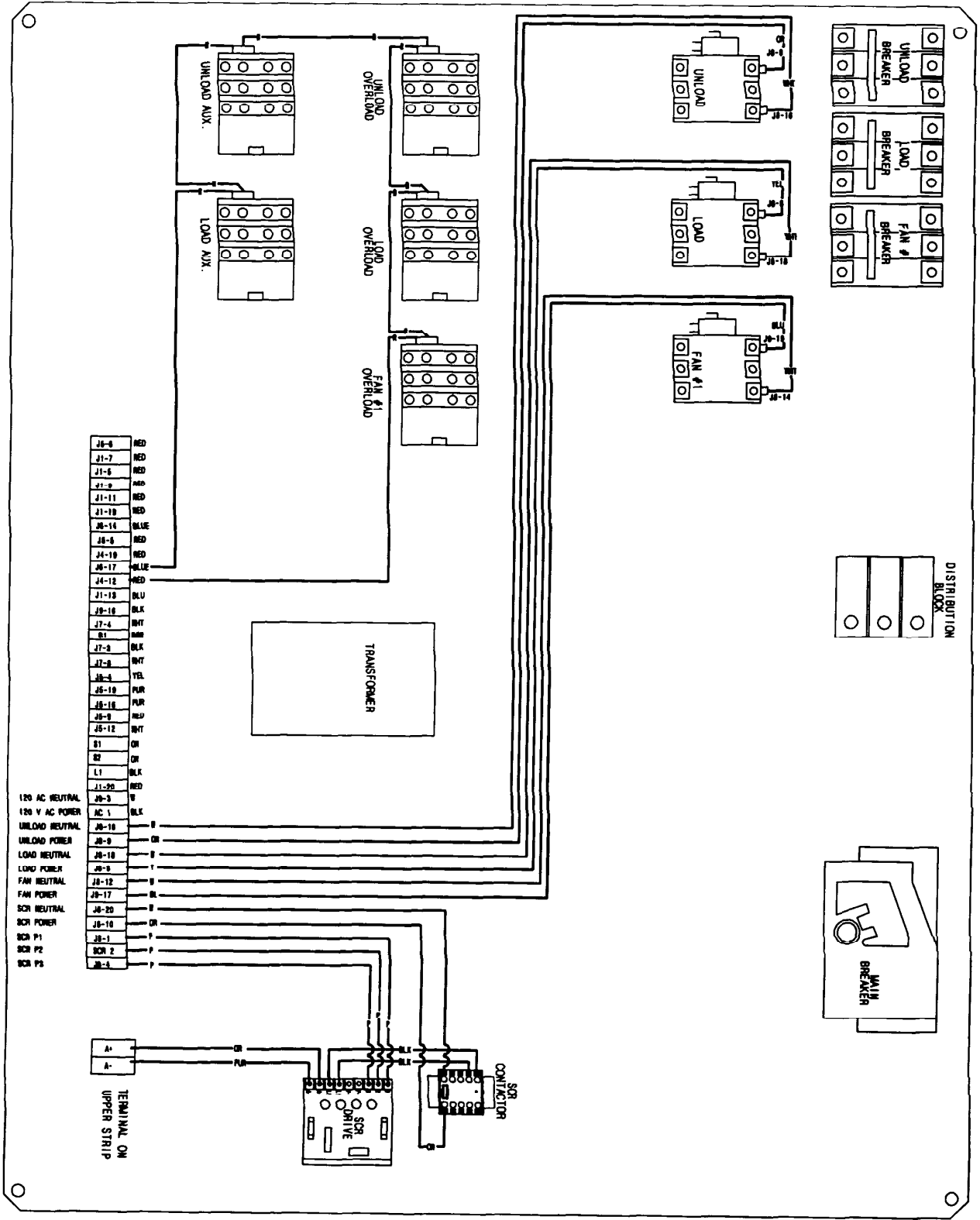

# SERVICE

## I 100 SERIES SAFETY WIRING DIAGRAM

MAY 26 1994

SAFETY DESCRIPTION J5-8 (12 VOLTS DC)

TERMINAL ON INPUT/OUTPUT BOARD

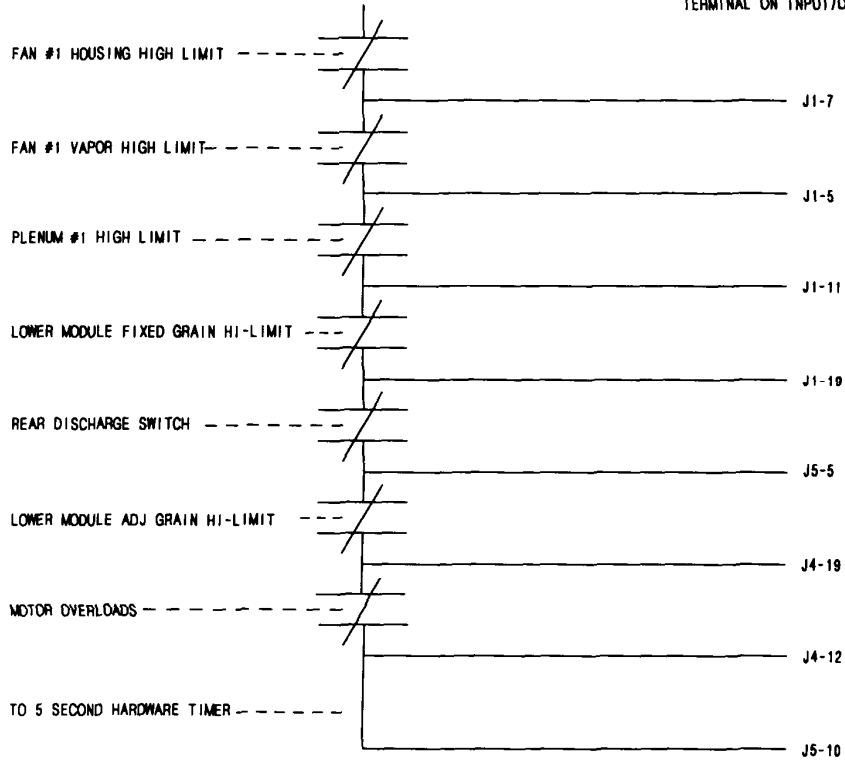

### FLAME DETECTOR SHUTDOWN CIRCUIT

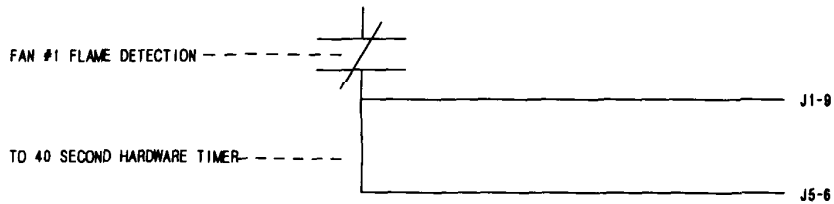

### J5-8 (12 VOLTS DC)

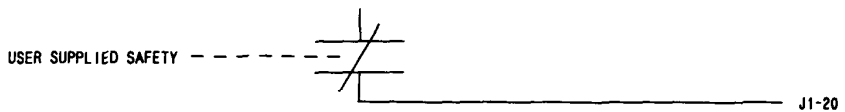

# SERVICE

## I 100 SERIES FRONT PANEL INTERNAL WIRING

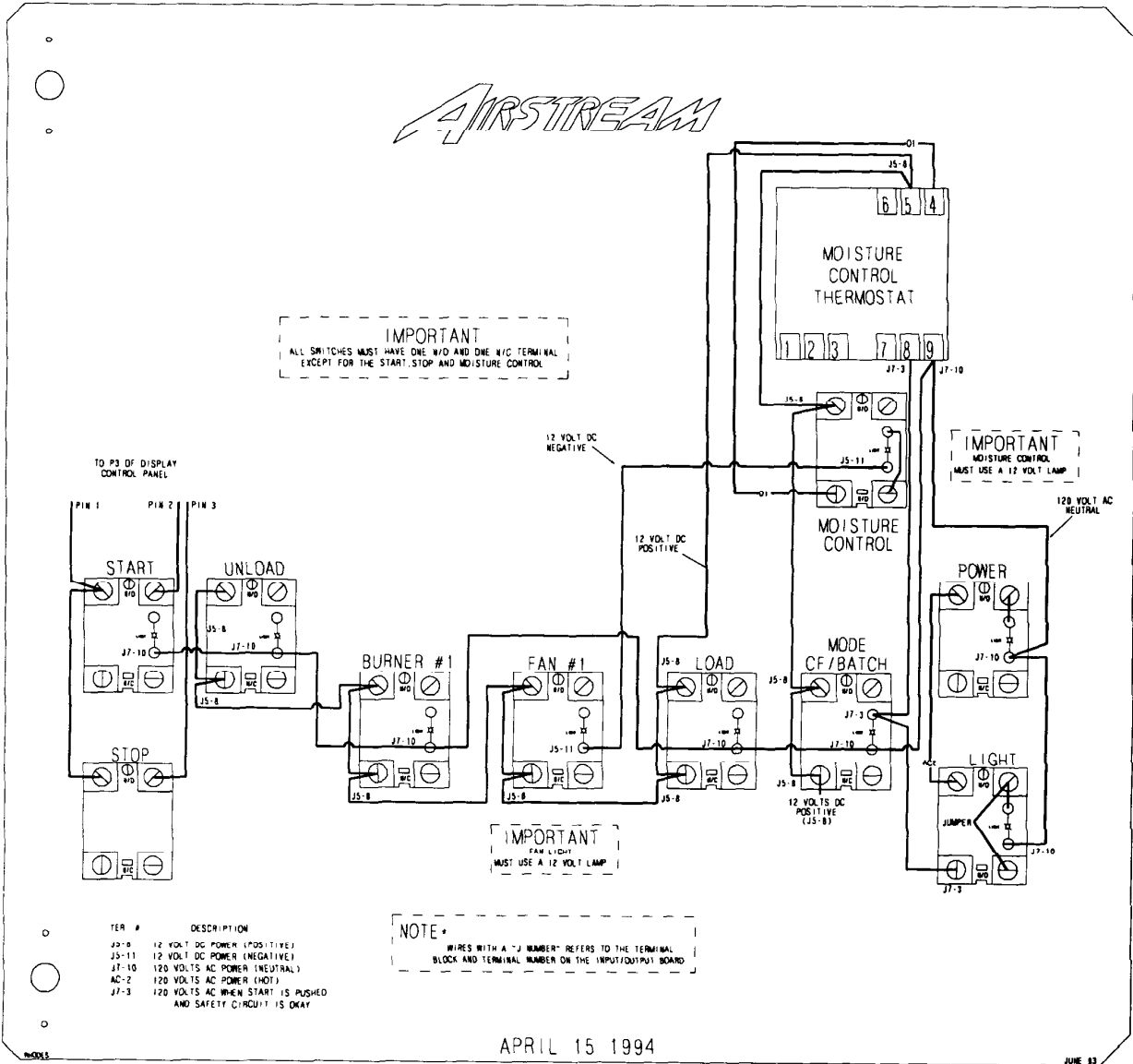



# SERVICE

## I 100 SERIES FRONT PANEL EXTERNAL WIRING

*AIRSTREAM*

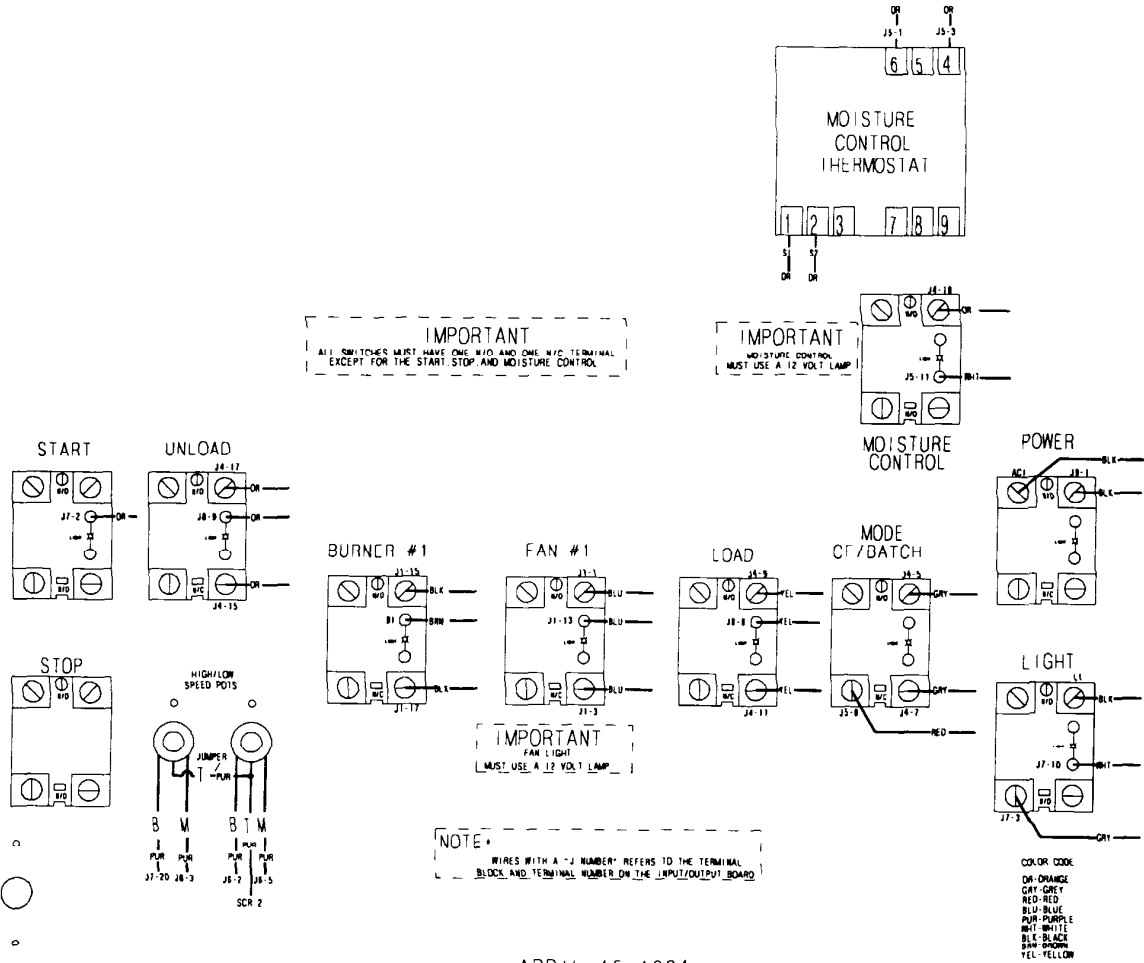

APRIL 15 1994

JUNE 83

# SERVICE

## DRYER FAN CAN CONTROL WIRING

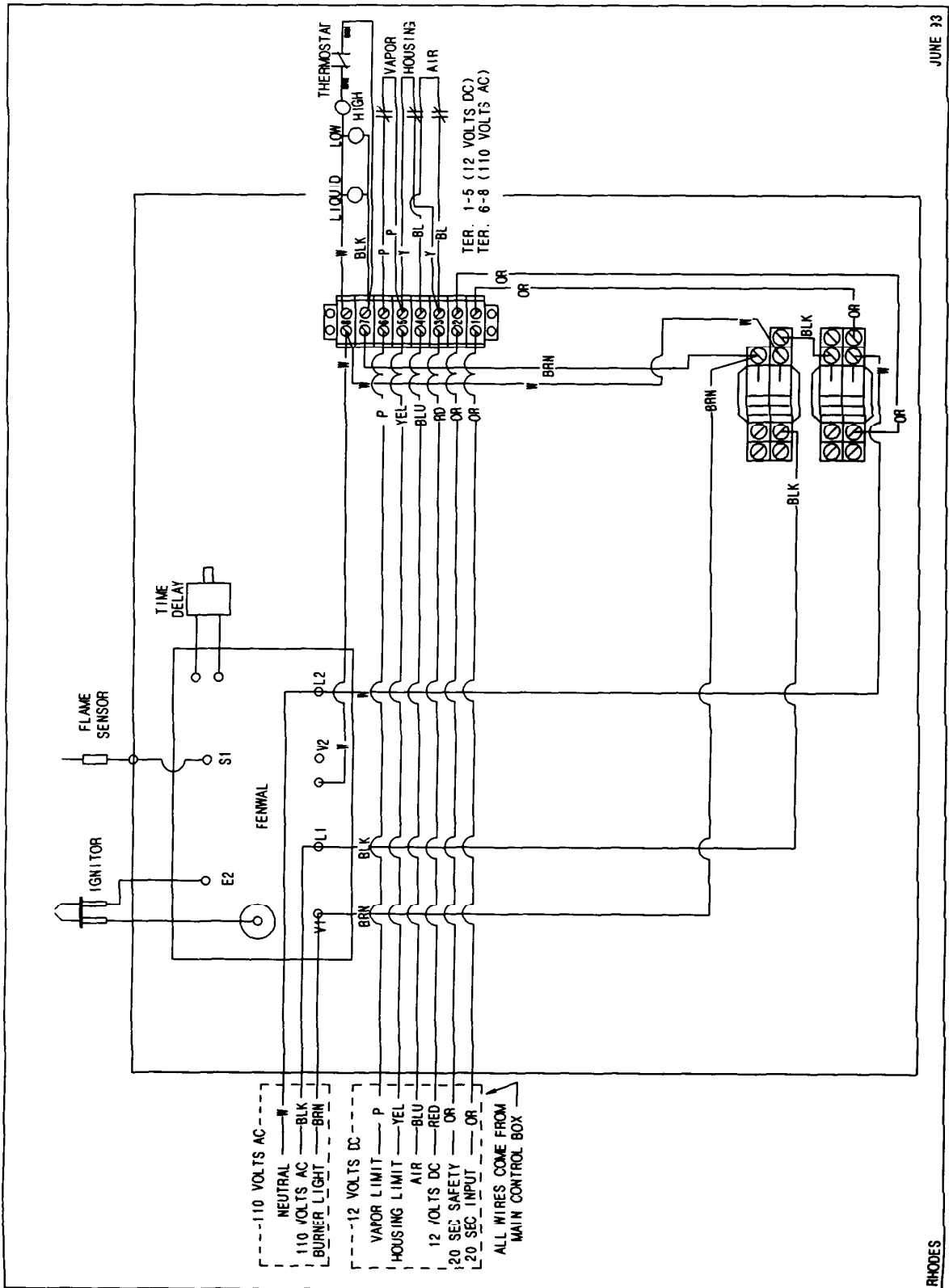

JUNE 33

RHODES

# SERVICE

## I 100 SERIES 220 VOLT SINGLE PHASE CONTROL WIRING

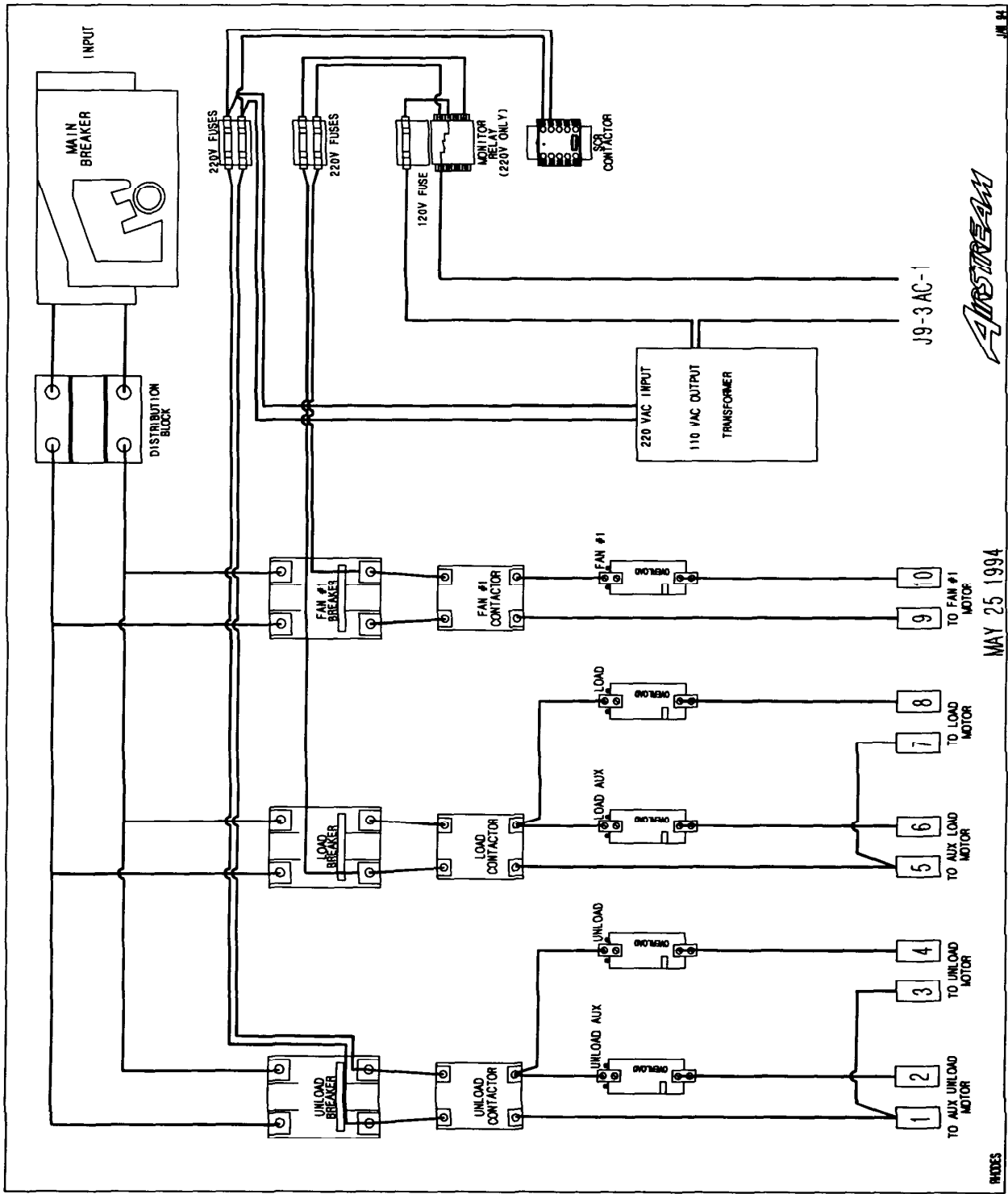

# SERVICE

## I 100 SERIES 220 VOLT 3 PHASE POWER WIRING

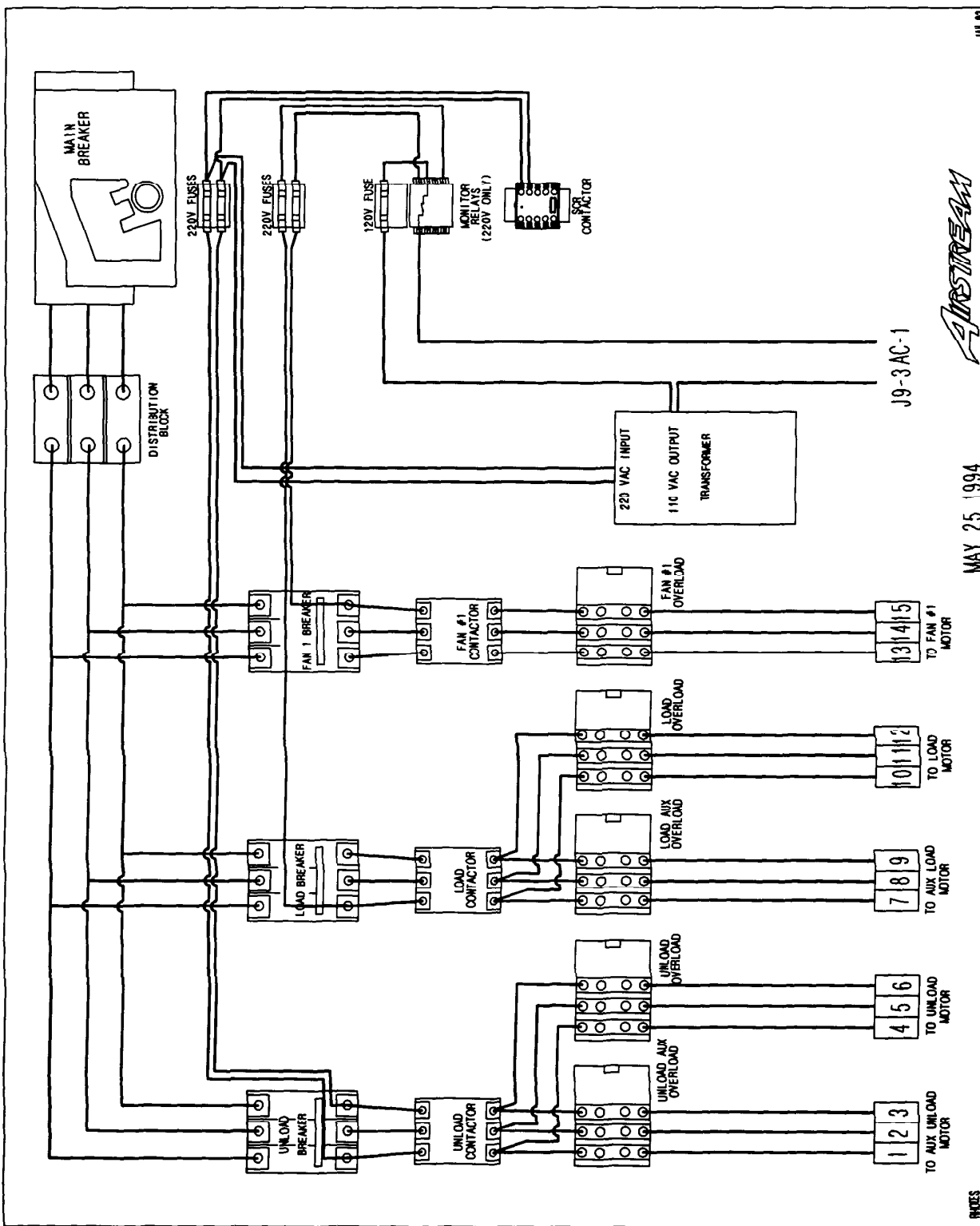

# SERVICE

## 1100 SERIES 440 VOLT 3 PHASE POWER WIRING

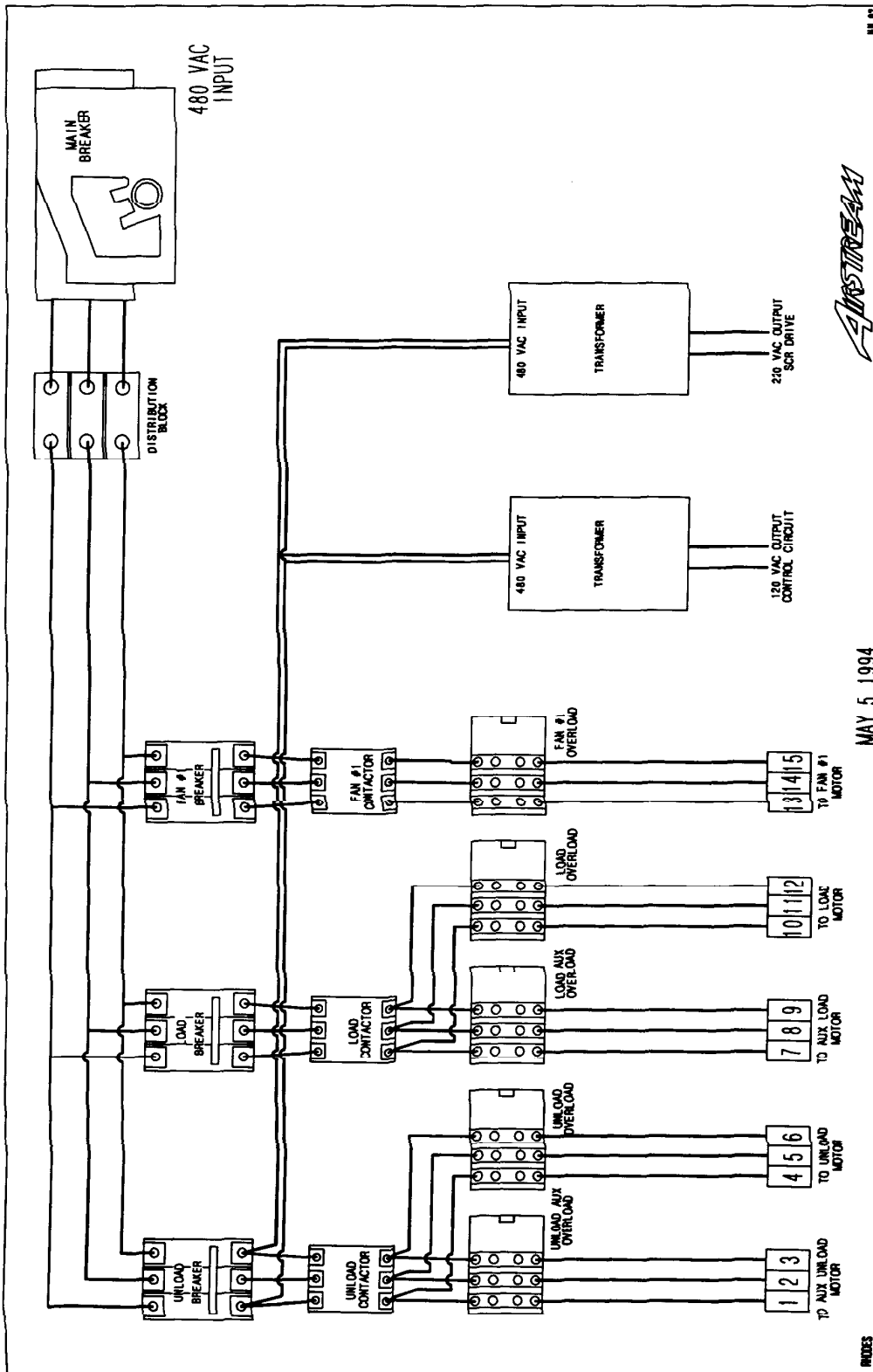

# SERVICE

## TROUBLE ANALYSIS PROCEDURE

A multimeter is required for some of the following check-out procedures. Before performing any tests, make certain if the dryer power supply is 1 phase, 230 volt, or 3 phase, 230 or 460 volt.

- The burner circuit is 120 volts AC on all standard U. S. production models.
- The control circuit to the motor starters is 120 volts AC.

- The safety circuit is 12 volts D. C.
- When checking these circuits, measure voltage between the circuit test location and to ground.
- D. C. circuits should be measured between the test location and its respective D. C. ground.

Refer to wiring diagrams and the parts list for identification of parts and the electrical terminals.

**CAUTION:** When making high voltage tests with "live" circuits, be extremely careful. Follow established safety practices. Turn power on for testing only. Do not attempt to make the dryer operate by using a jumper wire to bypass a defective safety component.

Problem	Possible Cause
Control power switch light off.	<ol style="list-style-type: none"> <li>1. Check that main power and circuit breakers are turned on. Check for tripped breaker.</li> <li>2. Check for blown 5 amp fuses.</li> <li>3. Monitor relay is defective.</li> <li>4. Defective transformer or wiring.</li> <li>5. Check for a defective power switch.</li> <li>6. Check wiring between fuses and input/output board. Refer to wiring diagram for test locations.</li> </ol>
<p>Control power light is on, reset button has been pressed, drying mode light off.</p> <p>This indicates control power is present at input/output board, but no power is being transferred through the I/O board.</p>	<ol style="list-style-type: none"> <li>1. <b>Power interruption:</b> Incoming power to the dryer has been interrupted. The display screen will show the date and time if this has occurred, once power has returned.</li> <li>2. <b>Display not finished initial setup:</b> The monitor will display a copyright message and model number, total running time in hours and minutes and then the current date and time. To activate the controller press the reset button.</li> <li>3. <b>Input/output board:</b> The input/output board has developed a problem that requires its replacement.</li> </ol>
No display on LCD screen.	<ol style="list-style-type: none"> <li>1. Check for a defective power switch.</li> <li>2. Check wiring between fuses and input/output board.</li> <li>3. Check for 120 volts A. C. between points J9-3 and AC-1.</li> <li>4. The display may have a malfunction requiring its replacement.</li> </ol>
Control power light is on, drying mode light is on--load auger, fan, heater, unload auger will not operate.	<ol style="list-style-type: none"> <li>1. <b>Press the dryer power</b> start button.</li> <li>2. Refer to the problem listed for load auger, fan heater and unload auger in the following sections.</li> </ol>
Display shows " <b>L1 VOLTAGE LOST</b> " message.	The left circuit breaker located on the input/output board of the Electronic Monitoring Control System has tripped, or one of the hardware timers on the Electronic Monitoring Control System has shut down the dryer.
Display shows " <b>12 VOLT POWER SUPPLY WARNING</b> " message.	The right circuit breaker located on the input/output board of the Electronic Monitoring Control System has tripped.

# SERVICE

Problem	Possible Cause
Display shows " <b>MOTOR OVERLOAD</b> " message.	The thermal overload on the fan motor, load motor, unload motor or an auxiliary motor has opened indicating an overloaded motor. (The overloads must be manually reset).
Display shows " <b>BURNER 1 VAPOR HIGH TEMPERATURE</b> " message.	The LP gas vapor temperature sensor located in the gas train downstream from the vaporizer has opened, indicating that the vaporizer is running too hot and must be readjusted. (This control is a 200°F limit which automatically resets when it cools).
Display shows " <b>BURNER 1 WARNING FLAME NOT DETECTED</b> " message.	The flame sensor has failed to detect a burner flame, indicating that the burner has failed to light, there is a problem with the flame sensing circuitry or the dryer is not getting burner fuel.
Display shows " <b>FAN 1 HOUSING HIGH TEMPERATURE</b> " message.	The temperature high limit located on the fan/burner housing has opened, indicating an over temperature condition has occurred towards the rear of the fan/heater housing. (This control is a 200°F limit control that must be manually reset).
Display shows " <b>GRAIN DISCHARGE WARNING</b> " message.	The cover on the grain discharge box has opened, indicating that grain is backing up into the discharge box.
Display shows " <b>LOWER ADJ. GRAIN HIGH TEMPERATURE</b> " message.	An over temperature condition has occurred inside the left side grain column. (This control is a 210°F limit which automatically resets when it cools).
Display shows " <b>LOWER FIXED GRAIN HIGH TEMPERATURE</b> " message.	An over temperature condition has occurred inside the right side grain column. (This control is a 210°F limit which automatically resets when it cools).
Display shows " <b>OUT OF GRAIN</b> " message. Display shows " <b>OUT OF GRAIN-UNLOAD CLEANOUT..</b> " message.	The dryer has run low on grain, and the out of grain timer has timed out shutting the dryer down. The unload auger will then clean out the dryer, if the unload switch is on during continuous flow operation. Check the out of grain timer setting, and if necessary adjust. Also, before restarting, inspect load equipment for possible damage or adjustment.
Display shows " <b>PLENUM 1 HIGH TEMPERATURE</b> " message.	An over temperature condition has occurred inside the dryer plenum. (This control is a 300°F limit which automatically resets when it cools).
Display shows " <b>METER ROLL DRIVE SYSTEM FAILURE</b> " message.	The metering roll drive system has failed to turn within two minutes. A faulty D. C. motor, broken chain or jammed roll is a possible cause of this message.
Display shows " <b>RIGHT METERING ROLL FAILURE</b> " message.	The right metering roll has stopped rotating, or the sensor has been damaged.
Display shows " <b>LEFT METERING ROLL FAILURE</b> " message.	The left metering roll has stopped rotating, or the sensor has been damaged.
Display shows " <b>AUXILIARY SAFETY SHUTDOWN</b> " message.	A shutdown has occurred due to a user installed safety feature. This circuit is located between J5-9 and J1-20 terminals on the input/output board.
Display shows " <b>BURNER 1 SHUTDOWN LOSS OF AIRFLOW</b> " message.	The air switch contacts have opened, indicating insufficient airflow for burner to operate.

# SERVICE

Problem	Possible Cause
Display shows <b>"FAN 1 FAILURE-NO AIRFLOW"</b> message.	The air switch contacts have opened, indicating the fan may not be turning. The air switch may need adjustment.
Display shows <b>"FAN 1 CANNOT START-CHECK AIR SWITCH"</b> message.	The air switch contacts have closed prior to the fan starting, indicating a freewheeling blade or improper setting of air switch.
Fan motor will not start.	<ol style="list-style-type: none"> <li>1. Check that the fan circuit breaker and the fan switch are on. Also, check for defective switch or bad wiring connections.</li> <li>2. If lighted switch does not light, the air switch needs adjustment, or the bulb may be burned out.</li> <li>3. Verify closing of fan motor contactor. Check voltage on load side of contactor. See appropriate power wiring circuit diagram for terminal numbers. Inspect contactor for defective points or a burned out coil.</li> <li>4. Inspect connections, and check voltage applied to the motor leads in the fan heater box to determine if the motor is defective.</li> <li>5. Check capacitors on single phase motors, and replace if defective. If motor starts slowly, check for low voltage during starting due to excessive voltage drop in power supply wiring.</li> </ol>
Top auger will not start.	<ol style="list-style-type: none"> <li>1. Check that the top auger circuit breaker and the load auger switch are turned on.</li> <li>2. If lighted switch does not light, the output power to the contactor is missing. Check connections, or if the bulb is burned out.</li> <li>3. Check position of the upper auger paddle switch. It must be down to start auger.</li> <li>4. Inspect for secure mounting and wiring of mercury switch in the terminal box on the top auger paddle switch shaft. Include check for a defective mercury switch.</li> <li>5. Verify closing of the top auger contactor. Check voltage on load side of contactor. Inspect contactor for defective points, or a burned out coil.</li> <li>6. Inspect connections, and check voltage applied to motor leads in motor junction box to determine if motor is defective.</li> <li>7. Check that the mercury switch box is in the proper position.</li> </ol>
Bottom auger will not start.	<ol style="list-style-type: none"> <li>1. Check that the bottom auger circuit breaker is on.</li> <li>2. If the lighted switch does not light, the output power to the contractor is missing. Check connections, and check to see if the bulb is burned out.</li> <li>3. Check that the unload switch is on (1 or 2 speed).</li> <li>4. Verify closing of bottom auger contactor; check voltage on load side of contactor.</li> <li>5. If using the moisture control, check for proper setting, or defective operation of the control.</li> <li>6. Check for any loose wire connections in unload auger and moisture control thermostat circuits.</li> </ol>
Grain not moving through columns.	<ol style="list-style-type: none"> <li>1. Check the dryer for fine material buildup inside the columns.</li> <li>2. Avoid leaving the dryer columns full for long periods at a time (2-3 days) while not operating the dryer, or during rainy weather.</li> </ol>



# SERVICE

Problem	Possible Cause
Grain not moving through columns.	<ol style="list-style-type: none"> <li>1. Check the dryer for fine material buildup inside the columns.</li> <li>2. Avoid leaving the dryer columns full for long periods at a time (2-3 days) while not operating the dryer or during rainy weather.</li> <li>3. Empty the dryer. Keep the dryer clean! Do not allow fine material to gather in the plenum chamber.</li> <li>4. It may be necessary to open the strike off plates in the affected columns in half inch intervals.</li> </ol>
Uneven drying-Some kernels appear brown while others are under dried.	<ol style="list-style-type: none"> <li>1. Check plenum thermostat temperature setting. Some varieties of grain are more sensitive to higher operating temperatures. It may be necessary to lower the plenum operating temperature to accommodate this.</li> </ol>
Uneven heat exiting from dryer columns.	<ol style="list-style-type: none"> <li>2. Check for proper burner alignment (side to side). Vibration during shipment may have caused misalignment.</li> </ol>
Burner will not fire with fan operating.	<ol style="list-style-type: none"> <li>1. Burner switch must be on.</li> <li>2. Check for power to ignition board.</li> </ol>
Heater switch light and gas solenoids go on and off erratically-The light blinks on and off while the solenoids "chatter".	<ol style="list-style-type: none"> <li>1. The blinking light indicates the flame sensor is not detecting flame.</li> <li>2. The "chattering" solenoids are caused by the loss of flame detection, and the thermostat and Fenwal ignition board trying to reestablish a flame. Check for loose wires on flame sensor; replace or repair wires or sensor.</li> </ol>
Burner will not fire-No gas pressure with fan operating at least 15 seconds (gas supply or fan heater malfunction).	<ol style="list-style-type: none"> <li>1. Check gas supply. Also, check gas filter and gas line for possible obstruction or closed valves. Refill tank; replace or repair parts, as required.</li> <li>2. Inspect gas solenoid valves (including liquid valve on LP units) for defective coils or improper wiring. Replace valve or coil if valve will not open with proper voltage applied (115 volts).</li> <li>3. Check for proper voltage. 115 volts across L1 and L2 incoming voltage to the Fenwal Ignition Board, and 115 volts outgoing across V1 and V2 to the solenoids.</li> </ol>
Burner will not fire-But gauge shows gas pressure.	<ol style="list-style-type: none"> <li>1. Fenwal Ignition Board: Check board for spark by removing ignition wire from board, and holding an insulated screwdriver against the output terminal and 1/4" away from the control box casing. There should be a strong spark. Check board wire connections. Replace the Fenwal board, if necessary.</li> <li>2. Ignitor: Check that the ignitor is properly gapped to 1/8" and that it has a strong spark. Inspect the porcelain and electrodes for damage or cracking. Replace or clean if necessary.</li> </ol>
Burner maintains desired drying temperature-but cycles from hi-fire to off (without going to lo-fire).	<ol style="list-style-type: none"> <li>1. Make sure the low flow control valve is not completely closed. Valve must be adjusted open to provide the proper lo-fire gas pressure listed in this manual.</li> <li>2. Check lo-fire solenoid valve for proper operation.</li> </ol>

## SERVICE

Problem	Possible Cause
Burner operates-But will not cycle from hi-fire to lo-fire.	<ol style="list-style-type: none"><li>1. Check the gas pressure reading on the gauge. Problem may be due to insufficient gas regulator setting. Temporarily decrease the hi-lo fire thermostat setting to verify that the thermostat will function and cause the burner to cycle. If burner will cycle at the reduced thermostat setting, it indicates that the problem was due to insufficient heat to satisfy the original setting. Increase the gas regulator setting for additional heat output. Do not exceed the maximum pressure listed in this manual.</li><li>2. Hi-lo fire thermostat control may be defective. If the burner still will not cycle to lo-fire after decreasing the thermostat, the problem may be due to a broken or kinked thermostat sensor tube. Observe reading on the thermometer. Replace control assembly if it cannot be set to cause its switch to go to the open circuit position with normally hot air plenum temperatures.</li><li>3. If the burner continues to operate on hi-fire, check the hi-fire gas solenoid valve for a stuck or blocked open condition, or for reversed gas pipe connections. The solenoid valve must not allow gas flow when its coil is not energized.</li></ol>
Burner operates-But will not cycle from lo-fire to hi-fire.	<ol style="list-style-type: none"><li>1. Check for an excessive lo-fire gas pressure setting. Observe pressure setting shown on gauge, and compare reading with recommended low pressure settings listed in this manual. Readjust lo-fire setting on flow control valve, if necessary.</li><li>2. Check for improperly adjusted or defective hi-lo fire thermostat control. Temporarily increase the temperature setting. If the heater will still not cycle, check for problem in the control wire connections. The control wires should be connected to terminals R and B of the thermostat, so the switch will open upon temperature rise. If the burner will cycle with these two wires connected together, the thermostat is faulty.</li><li>3. Check for improperly connected or faulty hi-fire gas vapor solenoid valve. Correct any poor connections or defective wiring. If wiring appears proper, problem may be caused by a burned out valve coil or defective valve. Replace hi-fire solenoid valve, or its coil, if defective.</li></ol>

## QUICK REFERENCE GUIDE

### ELECTRONIC MONITORING CONTROL SYSTEM

Important! To activate the controller after turning on the control power, press the reset button.

To set the dry, cool, unload and out of grain timers:

- Press the **dry, cool, unload or out of grain** button
- Press the **modify** button
- Press the **increase or decrease** button to get desired setting
- Press the **enter** button when desired setting is reached

To set the load and unload delays:

- Press the **load or unload** button
- Press the **modify** button
- Press **increase or decrease** button to get desired setting
- Press the **enter** button when desired setting is reached

Pressing the **increase** and **decrease** buttons simultaneously will access the following programming features:

- Safety circuit shutdown log
- Dryer model number
- Fan delay

- BPH factor
- Fill auger options:
  - a. Center fill auger
  - b. End fill auger
- Metering roll monitor disabling feature
- Air switch disabling feature

These features are accessed sequentially as listed above. Press the **increase or decrease** buttons to change a setting. Press the **enter** button to move from feature to feature.

Pressing and holding the **reset** button for five seconds will access the following programming features:

- Calendar year setting
- Calendar month setting
- Calendar day setting
- Clock hour setting
- Clock minute setting
- Bushel counter reset
- Batch counter reset

These features are accessed sequentially as listed above. Press the **increase or decrease** buttons to change a setting. Press the **enter** but-

ton to move from feature to feature.

To change the marquee on the LCD display:

- Press and hold the **modify** button while turning on the **control power**
- Press the **increase or decrease** button to change a character
- Press the **unload** button to move the cursor to the right
- Press the **dry** button to move the cursor to the left
- Press the **cool** button to delete a character
- Press **enter** when the desired marquee is displayed

To reset the computer to the original default setting, turn off the computer, press and hold the **green AUX 1 button** and turn on the computer. NOVRAM will appear on the LCD display. The year, date, time and minutes may be changed now, and the shutdown history may also be cleared.

Note: If the history is cleared the dryer model number must be reset or only the bottom fan will operate (if so equipped).



Dryer owner and Airstream associates check the Electronic Monitoring Control System.





# AIRSTREAM GRAIN CONDITIONING SYSTEMS

**AIRSTREAM**  
a division of  
THE GSI GROUP



1004 E. Illinois St., Box 20  
Assumption, IL 62510-0020  
phone: 217-226-4421  
fax: 217-226-4498

November 1997